

Hydraulic --- Breaker

V5GS

Operating & Maintenance Manual



Due to our policy of continual product improvements,
designs and specifications in this manual are subject to change without advance notice

CONTENT

GENERAL INFORMATION	3
1. Introduction.....	3
2. Safety Precautions	3
SPECIFICATION	4
1. Hammer Specifications.....	4
2. Structure.....	6
OPERATION	7
1. Serial Number	7
2. Guide to Tool Choice.....	8
3. Installation and Removal of the Hammer	8
4. Setting of Relief Pressure	8
5. Operating Precautions.....	9
6. Operating Temperature.....	10
7. Hydraulic Circuit.....	10
8. Hydraulic Oil.....	10
9. Oil Filter.....	11
10. Oil Cooler.....	11
11. Lubrication	11
MAINTENANCE	12
1. Periodical Inspection & Schedule.....	12
2. General Precautions	13
3. Periodical Inspection & Schedule.....	13
4. Storage	13
5. Precautions for Delivery.....	14
6. Back Head Gas Charging.....	14
7. Side Rod Inspection & Replacement	15
8. Consumable Parts	15
9. Disassembly and Assembly.....	16
10. Tightening Torque Specifications.....	16
11. Wear Limit of Consumable Parts.....	17
TROUBLESHOOTING	18
1. Oil Leakage.....	18
2. No Impact	18
3. Irregular Blows after Normal Operation.....	18
4. Lack of Blows.....	18

ACCESSORY TOOLS..... 19

WARRANTY REPORT.....20

1. Introduction

Preface

The aim of this manual is to give you a good understanding of the breaker. You will find instructions for safe and effective operation and instructions for regular maintenance activities of the breaker as well.

Before installation or operation of the breaker for the first time, please read and understand this manual carefully from front to back.

In this manual, the units of measurement are metric. In some cases imperial unit follows in parenthesis.

The specifications and designs presented in this manual are subject to change without prior notice.

2. Safety Precautions

Operation

- ◆ Operate the breaker for its intended purpose only.
- ◆ Operate the breaker only when the operator is seated in the cabin with full control of the machine.
- ◆ No bystanders are allowed in the vicinity of the breaker when it is operating. Small pieces of stone or concrete can fly off causing serious injury to bystanders.
- ◆ Stay clear of the breaker when it is operating
- ◆ Before operating the breaker, read and follow the safety decals located on the housing and power cell.
- ◆ Be sure that all decals are clearly visible. Clean and replace as necessary.

Protective equipment

- ◆ Always wear the following personal protective equipment: safety glasses, ear protection, protective gloves and protective shoes

Maintenance

- ◆ The back head is charged with nitrogen gas. Only use nitrogen gas to recharge it. Charging with any other gas could trigger an explosion and lead to serious or possibly fatal injuries.
- ◆ Make sure that all gas in the back head is completely relieved before beginning disassembly to avoid potential accidents or injury.
- ◆ Stay clear of the tool when recharging the back head. Gas pressure may lead unexpected piston movement and hence the tool movement.
- ◆ Do not substitute alternate parts not intended for the application. Failure to comply can result in machine failure.

Hot parts

- ◆ Never touch the hot parts and wait for them to cool down first if you have to touch them.
- ◆ Hot hydraulic oil can cause burns. Never use your fingers to check for hydraulic fluid leaks and always keep your face away from a possible leak.

SPECIFICATION

1. Hammer Specifications

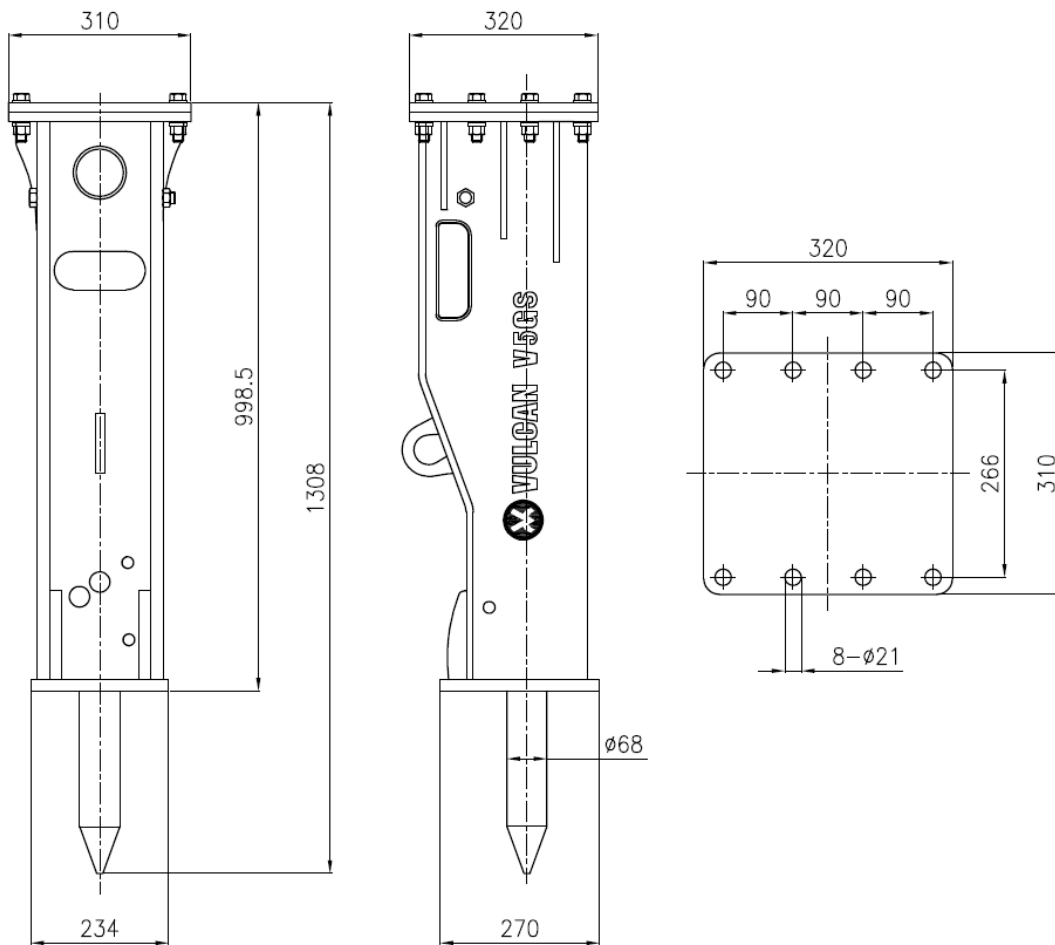

Item	Specifications
Working weight	300 kg (661 lbs)
Impact rate	500 ~ 750 bpm
Operating pressure	95 ~ 130 bar (1375 ~ 1885 psi)
Relief pressure	150 ~ 170 bar (2175 ~ 2465 psi)
Oil flow	40 ~ 55 l/min (10.5 ~ 14.5 gpm)
Back pressure	10 bar (145 psi)
Tool diameter	68 mm (2.7 in)
Oil temperature	-20 ~ +80 °C (-4 ~ +176 °F)
Hydraulic oil viscosity	1000 ~ 15 cSt (131 ~ 2.35 °E)
Pressure line size	12 mm (1/2in)
Return line size	12 mm (1/2in)
Backhead pressure	16 bar (230 psi)
Carrier weight	4 ~ 8 tonne

SPECIFICATION

Tool Specifications

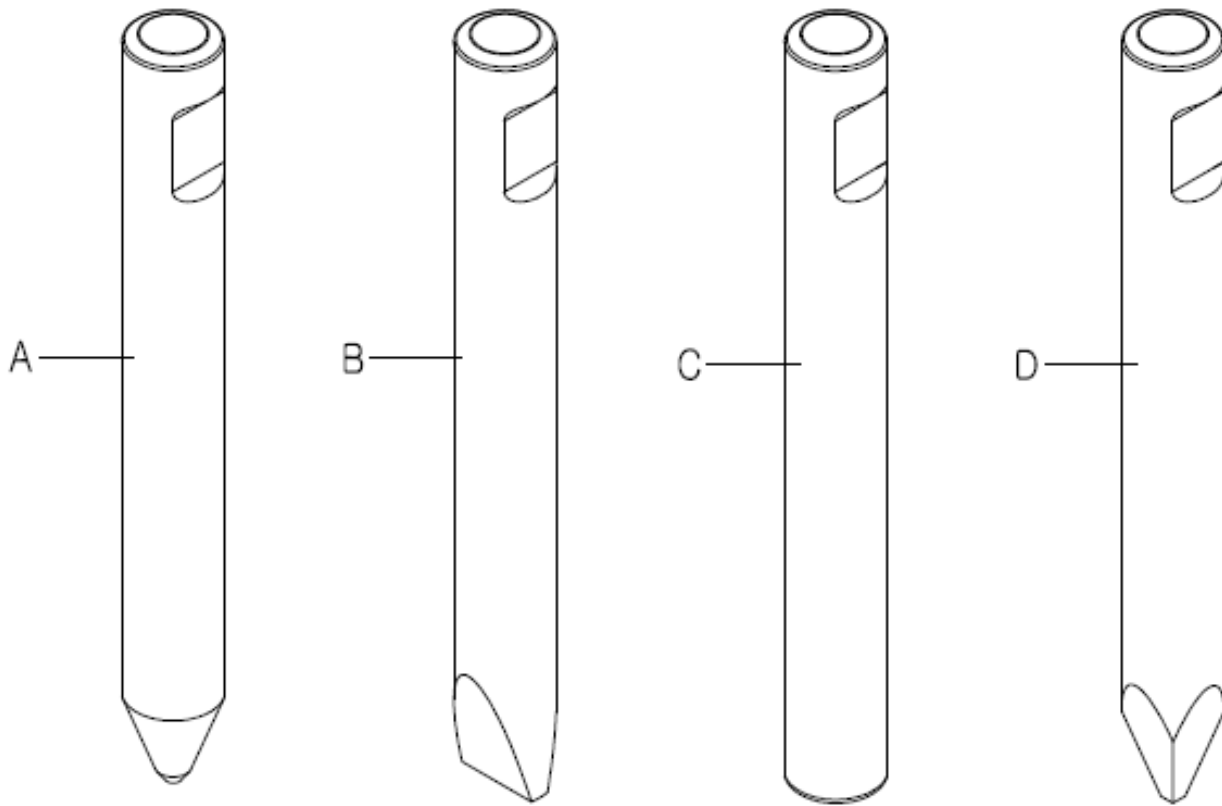

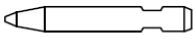
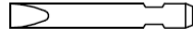
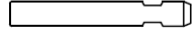
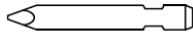
	Name	Length mm (in)	Weight kg (lbs)	Diameter mm (in)
◎ 	Cone tool (A)	697(27.44)	17.5(38.6)	68(2.68)
⊖ 	Chisel tool (B)	697(27.44)	17.5(38.6)	68(2.68)
○ 	Blunt tool (C)	697(27.44)	18.7(41)	68(2.68)
⊗ 	Moil tool (D)	697(27.44)	17(37.5)	68(2.68)

2. Structure

V5GS – V10GS

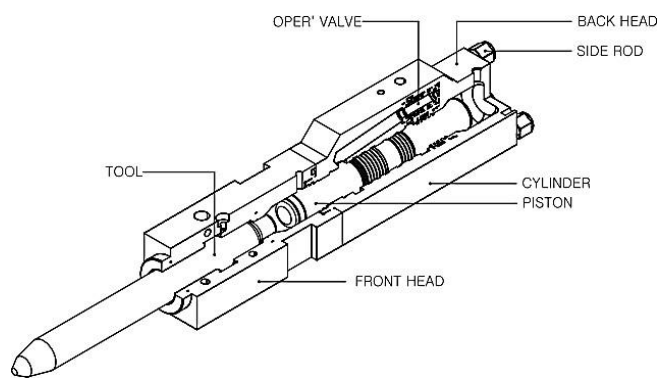

Side rod

Three major parts of the breaker, front head, cylinder and back head, are secured by four side rods.

Back head

Hydraulic ports along with nitrogen gas chamber are built into the back head.

Operating valve

Operation control valve is built into the cylinder and controls piston reciprocation.

Cylinder

Hydraulic circuit for reciprocating the piston is built into the cylinder.

Piston

Kinetic energy of the piston is converted into impact energy when it is transmitted to the working steel.

Front head

Front head holds the tool via thrust ring, upper bushing, and tool bushing.

Tool

Depending upon the application, cone, chisel, blunt ormoil tool can be used.

OPERATION

1. Serial Number

Identification of the product and part serial number is important when claiming warranty or ordering spare parts.

Product serial number

The product serial number is stamped on the back head.

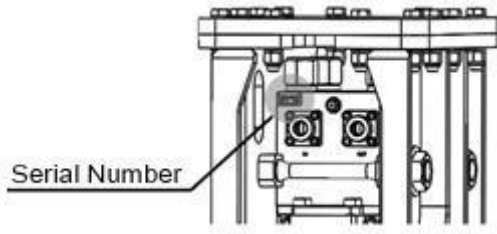

◆ Tool pin



◆ Tool bushing



Parts serial number

◆ Tool



◆ Piston

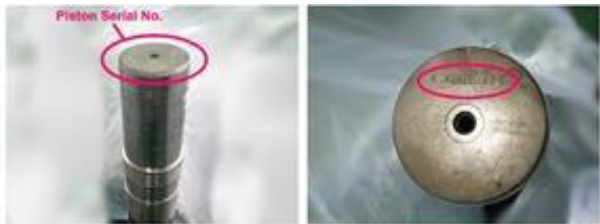

◆ Cylinder



◆ Front head



OPERATION

2. Guide to Tool Choice

The correct choice of the most suitable tool is crucial not only for increasing hydraulic breaker productivity but also for the life of the tool itself

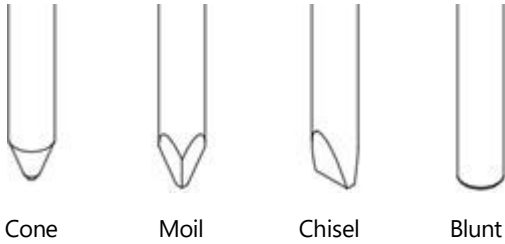

Cone, moil or chisel tools are suitable for most jobs. In trenching, benching and demolition applications, the material is broken by a combination of impact energy and a wedging effect that forces the material to separate as the tool penetrates. Cone is used for general demolition work where penetrative breaking is required. Moil is used where increased breakout forces are required. Chisel is preferred where a cutting action is required.

Blunt tool is suitable for secondary breaking, boulder reduction applications and scaling in mines or tunnels. The tool breaks the material with stress waves generated by the hammer, passing through the tool and into the material. Blunt provides an excellent combination of productivity and resistance to wear.

3. Installation and Removal of the Hammer

Installation

1. Before connecting the hammer, make sure to carry out flushing first to prevent the hammer from being contaminated by external particles from hoses etc.
2. Check and record the carrier pump performance as described in the Hammer Installation Card.
3. Position the hammer horizontally on the floor and install arm pin first and then link pin.
4. Connect hoses. Hammer inlet port is marked with "IN" and outlet port with "OUT".
5. Open the stop valves of carrier pressure and return lines.

Removal from carrier

1. Position the hammer horizontally.
2. Stop the carrier engine. Close the stop valves of carrier pressure and return lines.
3. Disconnect hoses. Protect environment from oil spills. Plug the hoses and the hammer inlet and outlet ports.
4. Remove link pin first and then arm pin.

4. Setting of Relief Pressure

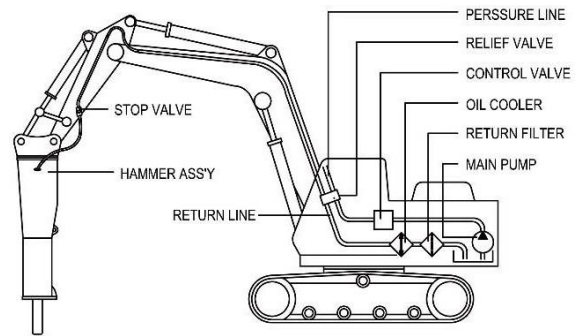

Relief valve

- ◆ The relief valve is a safety device which is used to protect the breaker when the pressure rises in hydraulic circuit.
- ◆ The relief pressure is measured from the carrier pressure line while closing the stop valve.
- ◆ The relief valve setting should be acceptable as per the specification of each model. Adjust if necessary.

5. Operating Precautions

- ◆ Keep the cabin windows and doors closed during operation

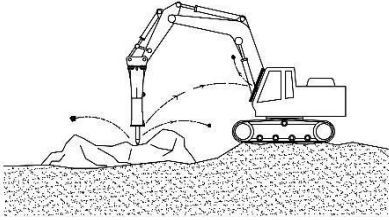

- ◆ Use the excavator boom to press the hammer firmly against the object.

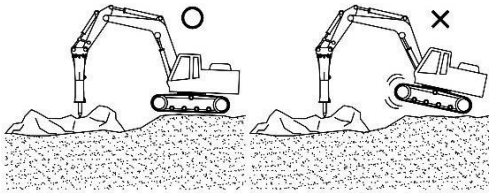

- ◆ Place the tool against the object at a 90 degree angle. Listen to the hammer's sound when you are using it. If the sound becomes thinner and the impact less efficient, the tool is misaligned with the material and/or there is not enough down force on the tool. Realign the tool and press the tool firmly against the material if necessary.

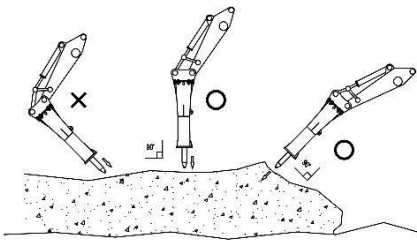

- ◆ When demolishing vertical structures, place the tool against the wall at a 90 degree angle.

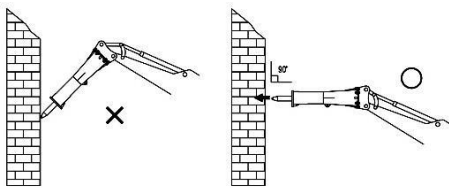

- ◆ Do not strike in one spot for more than 15 seconds at a time. If the object does not break, or if the tool does not penetrate, stop the hammer and change the position of the tool

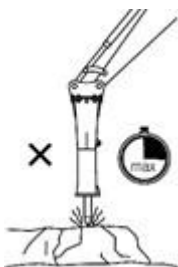

- ◆ When the object starts to break, stop the hammer immediately. Do not allow the hammer to fall down and make idle strokes. Frequent idle strokes would lead to deteriorating effects on the hammer components.

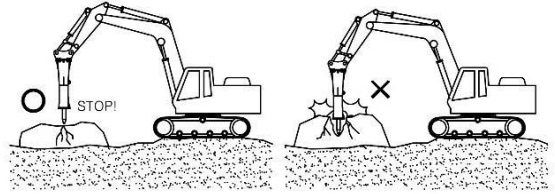

- ◆ When breaking concrete, hard or frozen ground, never strike and pry with the tool at the same time. The tool may snap off. Bending may be caused by stones inside hard or frozen ground. Be careful and stop striking if you find sudden resistance under the tool.

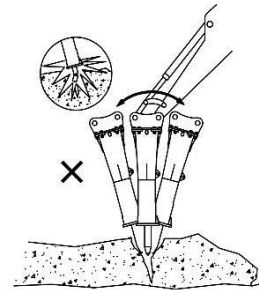

- ◆ Do not operate the hammer with the carrier's boom stick or bucket cylinders at the end of their stroke (either fully extended or fully retracted). This may result in damage to the carrier cylinder.

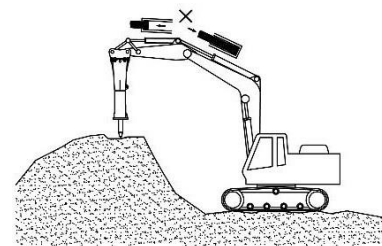

- ◆ The breaker as a standard assembly, must not be used under water. Please always contact Dealer or Customer Support in case of underwater application.

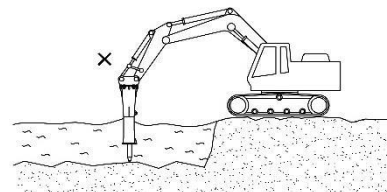

OPERATION

6. Operating Temperature

The optimized operating temperature of the hammer is $-20^{\circ}\text{C} \sim 80^{\circ}\text{C}$ ($-4^{\circ}\text{F} \sim +176^{\circ}\text{F}$). If the temperature is lower than -20°C (-4°F), the breaker and tool must be preheated before starting operation in order to avoid damage to the tool. During operation they will remain warm.

7. Hydraulic Circuit

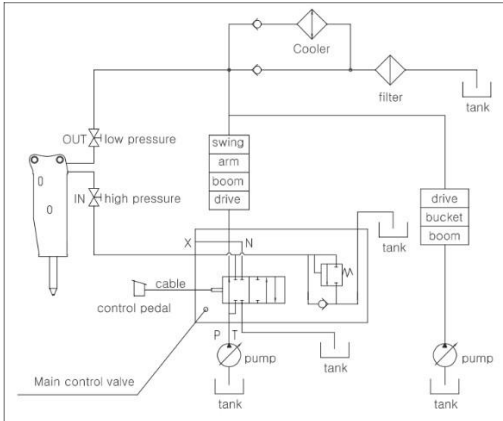

8. Hydraulic Oil

General requirements for hydraulic oil

In general, the hydraulic oil originally intended for the carrier can be used with this product. However, the temperature of the oil must be monitored. If the temperature of the hydraulic oil exceeds $+80^{\circ}\text{C}$, an auxiliary oil cooler is needed.

When the breaker is used continuously, the temperature of the hydraulic oil converges at a certain level depending on conditions of environment and the carrier. At this temperature, the viscosity of the hydraulic oil should be 20-40 cSt (2.90-5.35°E). The hammer should not start if the viscosity of the hydraulic oil is above 1000cSt (131 °E) or below 15cSt (2.35°E).

When the oil is too thick, the following problems may occur:

- ◆ Difficult start up
- ◆ Stiff operation
- ◆ Irregular and slow strike
- ◆ Danger of cavitation in the pumps and hydraulic breaker.
- ◆ Sticky valves
- ◆ Filter bypass, remaining of impurities in oil

When the oil is thin, the following problems may occur:

- ◆ Low efficiency (internal leaks)
- ◆ Leakage
- ◆ Accelerated component wearing due to decreased lubrication efficiency

Oil specifications

Table below shows hydraulic oils recommended for hammer use. The most suitable oil can be selected in such a way that the temperature of the hydraulic oil in continuous use is in the ideal recommended oil temperature area on the chart.

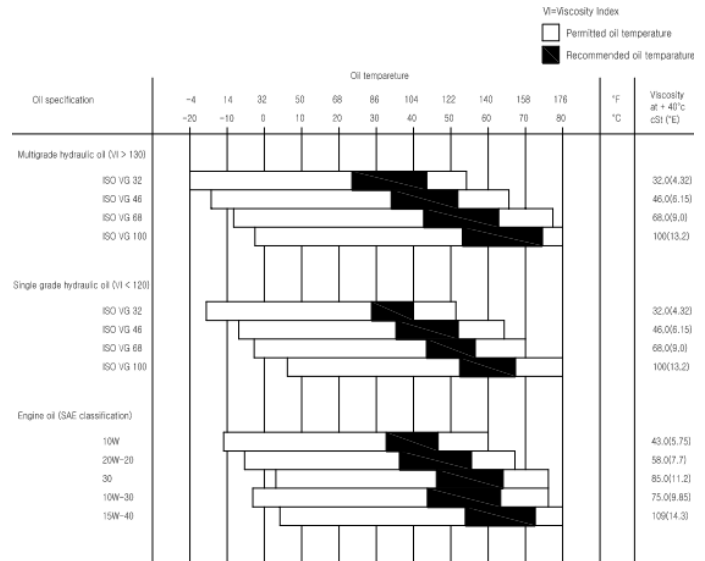

Special oils

When considering use of special oils (e.g. biological oils and non-inflammable oil), check if the viscosity range of the special oil is in the range of 15~1,000cSt. (2.35~131°E).

9. Oil Filter

The purpose of the oil filter is to remove impurities from the hydraulic oil. Impurities normally enter the carrier hydraulic system in case of repairing components or installing the hammer on the carrier.

Oil filter specifications

- ◆ The oil filter must allow maximum particle size of 25 microns.
- ◆ The oil filter material must be man-made fiber cloth or very fine gauge metallic mesh to withstand pressure fluctuations.
- ◆ The oil filter must have a nominal flow capacity of at least twice the hammer's max. flow
- ◆ In general, oil companies guarantee new oils to have a particle count of 40 microns maximum. Filter the oil when filling the tank.

Damage caused by hydraulic oil impurities

- ◆ Reduced working life of the pumps and other components
- ◆ Cavitation
- ◆ Oil leakage
- ◆ Oil overheating
- ◆ Oil quality deteriorates
- ◆ Electro-chemical changes in hydraulic oil
- ◆ Accelerated wear of moving parts and seals
- ◆ Reduced hammer efficiency
- ◆ Improper function of valves
- ◆ Piston seizing up
- ◆ Spools binding

10. Oil Cooler

The correct place to connect the hammer return line is between the oil cooler and the main filters. The hammer return line should not be connected before the oil cooler. Routing the hammer flow through the cooler, might damage either the cooler, due to pulsating flow, or the hammer, due to increased back pressure.

The carrier hydraulic system must be able to maintain the temperature within an acceptable level during the hammer operation because seals, wipers, membrane can normally withstand temperature up to 80°C and the higher the temperature is, the less oil viscosity becomes.

11. Lubrication

Proper hammer maintenance requires a sufficient supply of the correct grease to the tool.

Recommended is a lithium soap base NLGI grade 2 grease with Molybdenum Disulfide or other surface protecting additives and drop point of 260°C.

Greasing interval

- ◆ Tool shank must be well lubricated before installing tool.
- ◆ 20~30 strokes from grease gun to upper and lower bushings until grease comes out between the tool and the lower bushing.
- ◆ This should be done every 2 hours of operation.
- ◆ If the grease schedule cannot be controlled, then grease the hammer more often than required, for example, once every hour. It is far cheaper than replacing prematurely worn out tool or tool bushings.
- ◆ Insufficient greasing or use of improper grease may cause breakage of tool or abnormal wear of tool or tool bushings.

Correct greasing

When greasing, the hammer must be standing upright resting on the tool to ensure that the grease penetrates downwards between the tool and the tool bushing. This prevents grease from entering piston impact area and ensures proper distribution of grease between the tool and bushings.

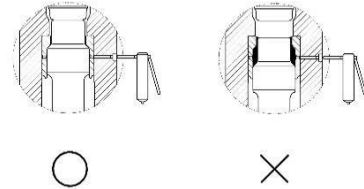

The greasing points on the hammer are marked with the sticker.

Automatic lubrication

Lubrication of the hammer can be made automatically by equipping the carrier with a lubrication pump. The tool grease is supplied from the pump into the hammer by hose. This is recommended for longer service life of wear parts.

MAINTENANCE

1. Periodical Inspection & Schedule

Parts	Inspection	Period				
		Every two hours	Once a week	Once a month	once every six months	Once a year
Greasing		○				
Tool	* Condition of wear			○		●
Tool Bush	* Condition of wear			○		●
Tool Pin	* Condition of wear			○		●
Thrust Ring	* Condition of wear			○		●
Upper Bush	* Condition of wear			○		●
Hydraulic Hose & Adapter	Leakage		○	△		
Back Head Gas Pressure	Leakage		○	△		
Side Rods Bolts	Loosening		○		△	○
Housing	Abrasion		○			△
Wear Plate	* Condition of wear				○	●
Housing Joint Bolts	Loosening		○		△	
Top Cover Bolts	Loosening		○		△	
Snap Ring	Breakage		○			●
Seal	Leakage		○			●
Oil Condition	Contamination					○
Oil Filter	Contamination				○	●
Main Carrier	Pressure / Oil Flow				○	

* Condition of wear: Determined according the wear limit

○: Checking

△: Re-tightening / Reinforcement / Recharge

●: Replacement

2. General Precautions

Maintenance instructions should be followed to ensure the breaker is operating in the best condition. Check every component of the machine before and after operating the breaker and repair or replace the related items if necessary for maximum durability.

Clean the machine before inspection

Breaker housing should be cleaned for removing dirt before inspection to ensure proper detection of damage of the breaker.

Keep away from the heat

Excavator, breaker body, hydraulic oil still have high level of temperature after certain operation. For this reason, do not touch any parts which have high temperature, wait until they are cooled down, otherwise it may cause serious injury.

Release pressure in the hydraulic system

Before disassembling hydraulic parts (e.g. hydraulic hose, plug, adjust bolt), make sure that stop valves on both hydraulic lines are fully closed and wait until the pressure in the hydraulic system of the machine are lowered to prevent hydraulic oil from popping out.

Keep record inspection history

Inspect the machine regularly and record the inspection result for future maintenance.

3. Periodical Inspection & Schedule

All the times below refer to the machine hours measured while the breaker is being installed.

Every 2 hours

- ◆ Grease the tool and the tool bushing

Every 10 hours or at least once a day

- ◆ Check the wear conditions of the tool and the tool pin. Grind off if necessary.
- ◆ Check if the tool has sufficient greasing. Grease if necessary.
- ◆ Check if the housing bolts and the top bracket bolts are loosened. Retighten if necessary.

Every 50 hours or at least once a week

- ◆ Remove the tool to inspect the tool, the tool bushing, and the bushing pin, and check the wear conditions thereof.
- ◆ Check the hydraulic hoses. Replace if damaged. Do not let dirt get into the hammer or the hoses.

- ◆ Check if the housing joint bolts and the top cover bolts are loosened. Replace or retighten if necessary.
- ◆ Check the gas pressure in the back head. Recharge if necessary.
- ◆ Check the hydraulic oil condition. Replace or refill if necessary.

Every 100 hours or at least once a month

- ◆ Check all the connection of hydraulic pipe line and in/out hoses.
- ◆ Check the operating pressure and the oil flow setting. Adjust if necessary.
- ◆ Check the relief pressure of the hydraulic system from the main carrier.

Every 600 hours or at least once a 6 month

- ◆ Make a regular exterior inspection (crack, loosening, oil leakage, etc.) of the breaker and the main carrier.
- ◆ Check every part of the power cell, the housing, and the bracket.
- ◆ Change all the seals.
- ◆ Check if the side rod bolts have cracks on the threads.
- ◆ Check all the hydraulic connections.
- ◆ Replace and inspect the hydraulic oil filters of the main carrier.

4. Storage

Short term storage

For short term storage between works, place the hammer horizontal on wooden blocks. Make sure that the tool is lubricated and the hydraulic hoses are securely capped. Cover the hammer with a waterproof tarp.

Long term storage

Check the following for safe long term storage of the hammer to prevent rust and to make the hammer ready to be used.

- ◆ Hammer must be stored in upright position.
- ◆ Discharge the gas pressure on the back head.
- ◆ Remove the tool and push the piston all the way in.
- ◆ Grease the exposed front end of the piston.
- ◆ Plug the hydraulic hoses.
- ◆ Cover the hammer with a waterproof tarp

MAINTENANCE

5. Precautions for Delivery

When the breaker is dispatched from the factory, back head is not charged with N₂ gas so that the piston is pushed back for rust prevention. Charge the back head before using the breaker.

6. Back Head Gas Charging

Never use anything other than Nitrogen gas for charging the back head.

Inspection of back head gas pressure

1. Install the gas pressure gauge on the charging block.
2. Close the screw of the charging block by turning it clockwise.
3. Remove plug from the charging valve of the back head and install the charging block.
4. Check the gas pressure while pushing the switch of the charging block.
5. Release the switch.
6. Open the screw of the charging block to discharge N₂ gas remaining in the gas hose.
7. Remove the charging block from the back head.
8. Install the plug of the back head.

Charging back head gas pressure

1. Install gas pressure gauge on charging block.
2. Connect gas hose to the charging block and N₂ gas tank.
3. Close the screw of the charging block by turning it clockwise.
4. Remove plug from the charging valve of the back head and install the charging block.
5. Open the handle of N₂ gas tank by turning it counterclockwise to charge the back head. Charge until the gas pressure level is about 5 bar above the specified gas pressure level.
6. Close the handle of N₂ gas tank by turning it clockwise.
7. While pushing the switch of the charging block, slightly open the screw of the charging block and drop the pressure level to the specified gas pressure level.
8. Close the screw of the charging block and release the switch.
9. Open the screw of the charging block to discharge N₂ gas remaining in the gas hose.
10. Remove the charging block from the back head.
11. Install the plug of the back head.

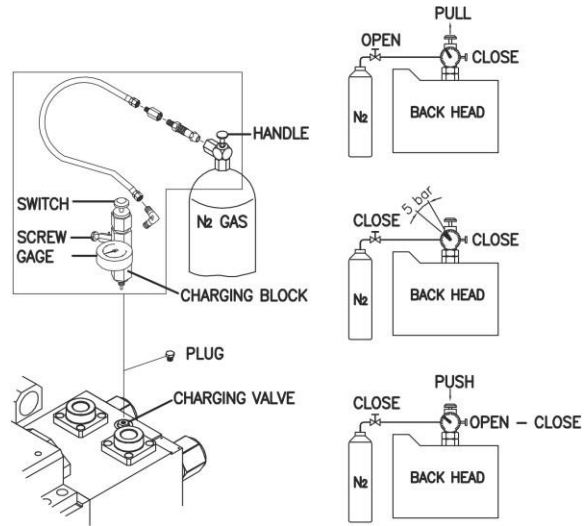

7. Side Rod Inspection & Replacement

Be sure to completely release back head gas pressure before loosening the side rods.

1. Discharge N₂ gas of the back head completely.
2. Remove the side rod nut and washer.
3. Remove the side rod, and inspect for any cracks and damages on the thread and shank.
4. Install the new side rod if necessary and tighten it using torque wrench with specified torque value as shown below.
5. When installing the side rods, tighten each rod one turn at a time in diagonal sequence. Do not make complete turn on one rod all at once.

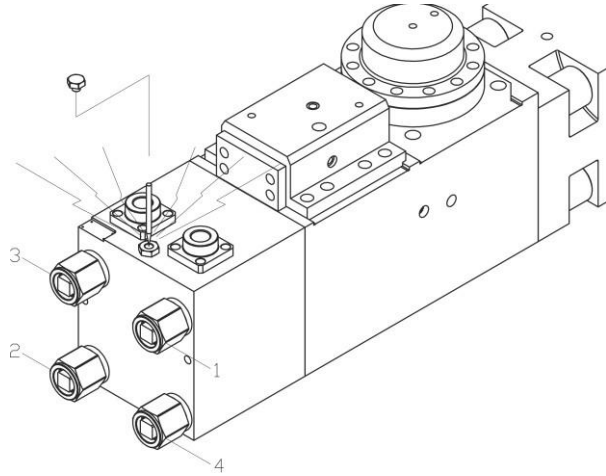

8. Consumable Parts

When damaged or worn, your attention is highly recommended to replace the consumable items below. Stocking of consumable items are highly recommended for proper maintenance

- ◆ Tool pins
 - ◆ Tool bushing & upper bushing
 - ◆ Stop pins & bushing pins
 - ◆ Side rods
 - ◆ Seals & O-rings
 - ◆ Hydraulic hoses
- ※ Replace hydraulic seals every 600 hours of operation.

※ When the tool pins are excessively worn out and deformed due to prolonged use, it is difficult to replace them. Every 100 to 150 hours of operation, change the face which comes in contact with the tool so that the wear is equally distributed

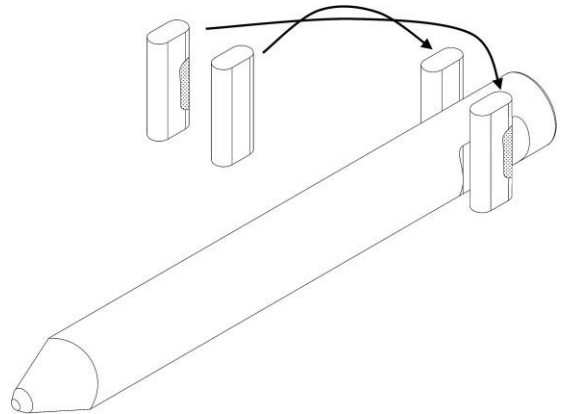

9. Disassembly and Assembly

Do not attempt to disassemble or assemble the hammer before reading this chapter of the manual.

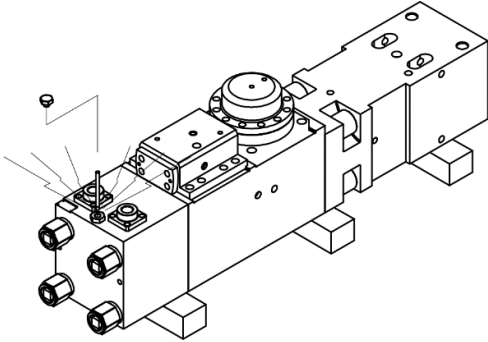

Disassembly

1. Put hammer on wooden supports.
2. Before dismantling the hammer, it is essential that N2 gas from back head is bled off.
3. Disassemble nuts of side rod from the hammer.
4. Disassemble back head by using eye bolts and hoist/chain block.

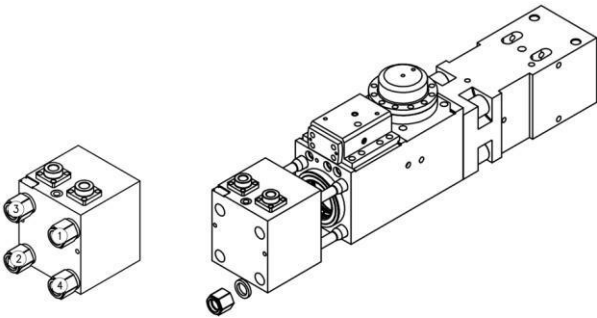

5. Disassemble cylinder by using eye bolts and hoist/chain block.

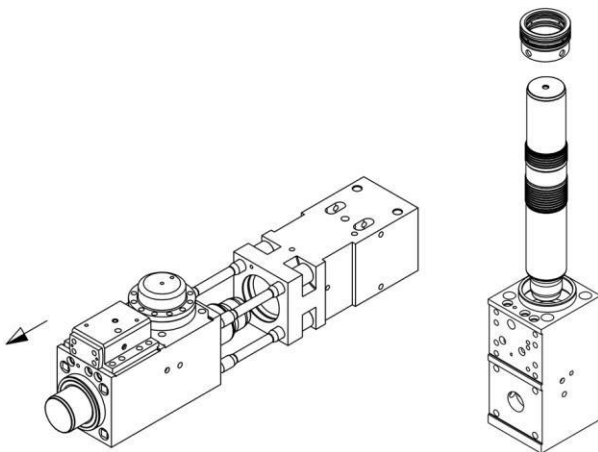

6. Disassemble piston by using eye bolt and hoist/chain block
7. Loosen and remove the side rods by rotating them counterclockwise. Use wrench or spanner to loosen them.

Assembly

◆ Seal assembly

Using a brush, lubricating oil should be applied to seal grooves before assembly. Handle seals with care.

◆ General assembly

1. Set the front head upright.
2. Assemble cylinder on the front head.
3. Lubricate piston thoroughly and slowly assemble piston.
4. Using a rubber hammer, assemble seal housing into the cylinder.
5. Assemble back head.
6. Assemble side rods and tighten the nuts to the specified torque.

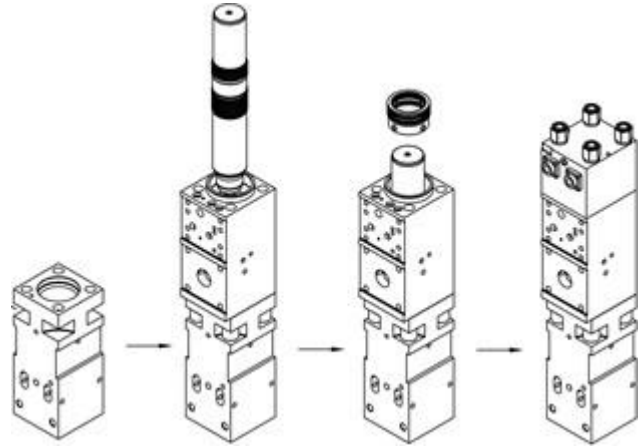

10. Tightening Torque Specifications

Item	N.m	Ft.Lbs
Side Rod	600	443
Housing Joint Bolt	800	590
Top Cover Bolt	300	221

MAINTENANCE

11. Wear Limit of Consumable Parts

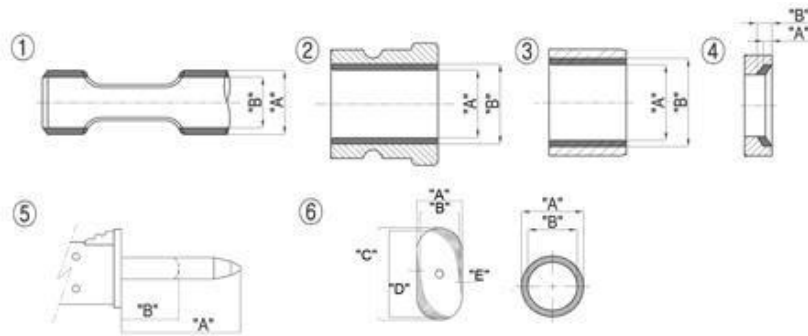

Model	① Tool		② Tool Bushing		③ Upper Bushing		④ Thrust Ring		⑤ Tool		⑥ Tool Pin				
	New (A)	Reject (B)	New (A)	Reject (B)	New (A)	Reject (B)	New (A)	Reject (B)	New (A)	Reject (B)	New (A)	Reject (B)	New (C)	Reject (D)	E
V5GS	68	66	68	70	68	70	-	-	382	250	30	27	-	-	-

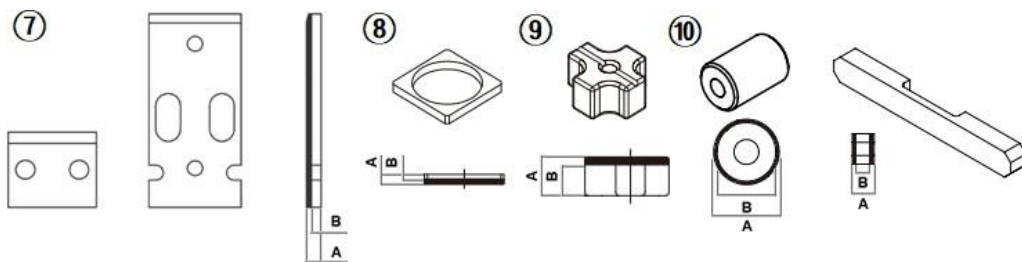

Model	⑦ Wearing Plate		⑧ Base Buffer		⑨ Top Buffer		⑩ Side Buffer	
	New (A)	Reject (B)	New (A)	Reject (B)	New (A)	Reject (B)	New (A)	Reject (B)
V5GS	12	10	20	18	70	68	50	48

1. Oil Leakage

- ◆ Between the tool and tool bushing
 - ▶ Small amount of oil coming from the area is for lubrication purposes and is normal. In case of large amount oil coming out, replace the damaged seals.
- ◆ Surface of breaker
 - ▶ Check the hydraulic hoses or bolts, side rods and retighten if necessary.

2. No Impact

- ◆ Oil temperature too low
 - ▶ Increase the oil temperature up to min 30°C.
- ◆ Back head gas pressure too low
 - ▶ Check the gas pressure and recharge if necessary.
- ◆ Relief valve pressure setting too low
 - ▶ Set the relief valve to the correct pressure setting.
- ◆ Poor performance of the carrier hydraulic pump
 - ▶ Contact the carrier manufacturer and check the carrier hydraulic pump performance and repair if necessary.
- ◆ Back pressure in return line too high
 - ▶ Check the cause of increased back pressure and remove.

3. Irregular Blows after Normal Operation

- ◆ Oil temperature too high
 - ▶ Check the oil cooler and oil level.
- ◆ Back head gas pressure too high
 - ▶ Check the gas pressure and adjust if necessary.
- ◆ Not enough down pressure on tool
 - ▶ Reposition the hammer and apply enough down pressure from the carrier.
- ◆ Clearance between the tool and tool bushing too large.
 - ▶ Check the clearance and replace the worn out parts.
- ◆ Too much grease in the impact chamber
 - ▶ Remove tool and clean out excess grease.
- ◆ Wear on the impact surface of the tool
 - ▶ Check the tool and replace if necessary.
- ◆ Seizure of piston and cylinder
 - ▶ Overhaul the hammer.

4. Lack of Blows

- ◆ Back head gas pressure too high
 - ▶ Check the gas pressure and adjust if necessary.
- ◆ Not enough down pressure on tool
 - ▶ Reposition the hammer and apply enough down pressure from the carrier.
- ◆ Relief valve pressure setting too low
 - ▶ Set the relief valve to the correct pressure setting.
- ◆ Poor performance of the carrier hydraulic pump
 - ▶ Contact the carrier manufacturer and check the carrier hydraulic pump performance and repair if necessary.
- ◆ Back pressure in return line too high
 - ▶ Check the cause of increased back pressure and remove.

ACCESSORY TOOLS

Model	Spec	V5GS	
		Open	Box
TOOL BOX	S	1	1
SINGLE SPANNER	27	2	2
	36	2	-
HAMMER SPANNER	41	1	1
L-WRENCH	8	1	1
T-WRENCH	5	1	1
PIN BAR	D15	1	1
GREASE GUN	500cc	1	1
DRIVER (-)	6x150	-	1

WARRANTY REPORT

Document No.

(Leave this area blank - to be filled out by the manufacturer)

1. PRODUCT INFO.

Serial number		Installation date	
<i>Note: If the installation card has not been submitted previously, it shall be sent along with this warranty report.</i>			

2. FAILURE INFO.

Failure date			
Symptom / Concern			
Repair / Action taken			
Status			
Image		Description	

3. PART REQUIRED

No.	Part number	Part name	Q'ty

4. DEALER INFO.

REQUESTED BY (Corporate name) _____

WRITTEN BY (Warranty report writer) _____

REPORTING DATE _____



VULCAN
ATTACHMENTS

769 PTH 75 Howden, MB R5A 1J3

Toll Free : 877-494-4303

Phone : 204-269-2680

info@vulcanattachments.com

www.VulcanAttachments.com