



VULCAN
ATTACHMENTS

Hydraulic Breaker

Vulcan V2GS

Operation

&

Maintenance Manual

CONTENTS

1. Specifications

- 1.1 General specifications for the V2GS
- 1.2 Tool specification
- 1.3 Structure

2. Operation

- 2.1 Product numbers
- 2.2 Tool Selection
- 2.3 Breaking Principles
- 2.4 Correct working methods
- 2.5 Operating Temperature
- 2.6 Important Operation Points
- 2.7 Storage
- 2.8 Mounting and Dismounting the Hammer
- 2.9 Operation Pressure Settings
- 2.10 Hose and Pipe Specification
- 2.11 Hydraulic Circuit

3. Lubrication

- 3.1 Manual Lubrication
- 3.2 Hydraulic Oil

4. Maintenance

- 4.1 Removal and Installation of Tools and Tool Bushings
- 4.2 Wear Limits of Tools and Tool Bushings
- 4.3 Disassembling and Assembling the Hammer Assembly
- 4.4 Disassembling and assembling the back head
- 4.5 Nitrogen gas charging device and method
- 4.6 Loosening and tightening side rods
- 4.7 Torques
- 4.8 Workshop tool list

CONTENTS

5. Troubleshooting Guide

- 5.1 Oil leakage
- 5.2 Irregular blows after normal beginning
- 5.3 No Impact

6. Generals and Safety Information

- 6.1 General
- 6.2 Safety

7. Parts List

- 7.1 Housing
- 7.2 Hammer Assembly

1 Specifications

1.1 General specifications for the V2GS (box)

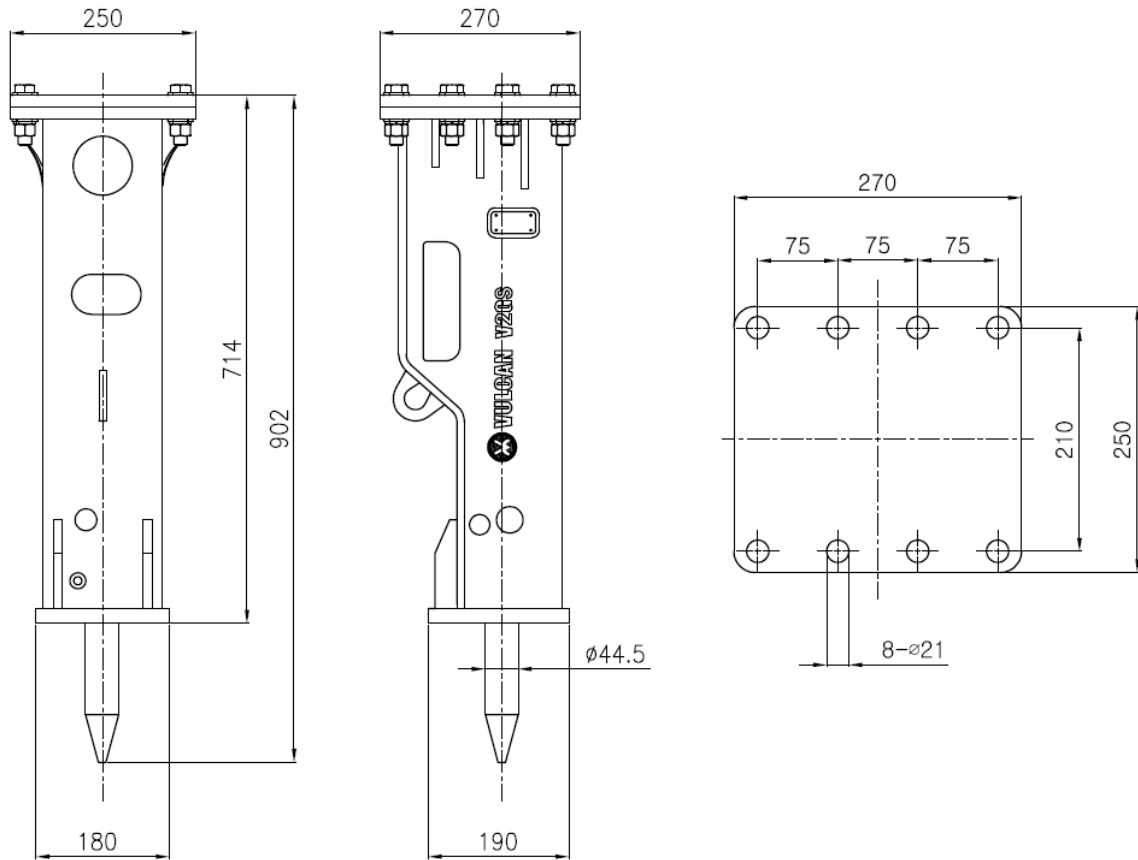

Item	Specifications
Working weight	105 kg (231 lb)
Impact frequency	800 ~ 1100 bpm
Operating pressure	90 ~ 120 bar (1305 ~ 1740 psi)
Relief pressure	140 ~ 160 bar
Oil Flow	15 ~ 30 l/min (4 ~ 8 gpm)
Back pressure	10 bar (145 psi)
Tool diameter	44.5 mm (1.75 in)
Oil temperature	-20 ~ +80 °C (-4 ~ +176 °F)
Hydraulic oil viscosity	1000~ 15 cSt (131 ~ 2.35 °E)
Pressure line size	12 mm (½in)
Return line size	12 mm (½in)
Back head pressure	8 bar (116 psi)
Carrier weight	0.8 ~ 2.5 ton

1.2 Tool specifications for the V2G

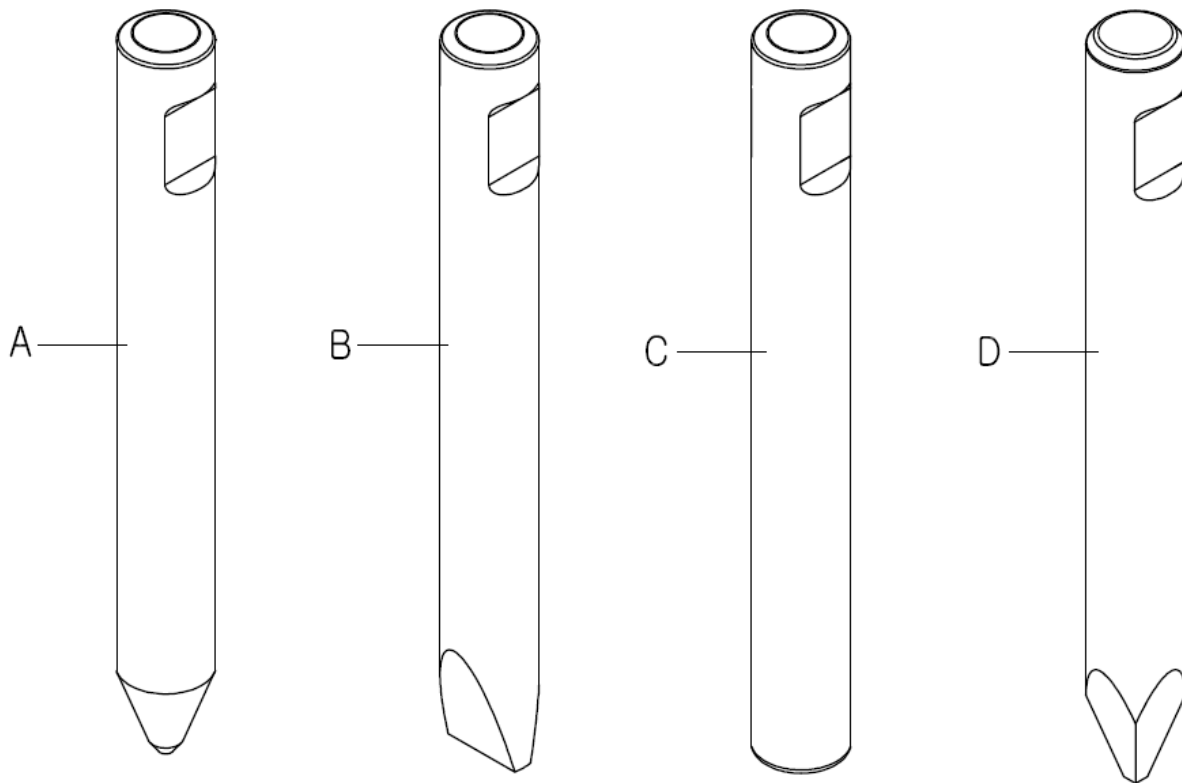

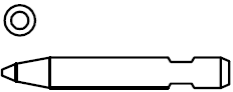
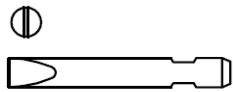
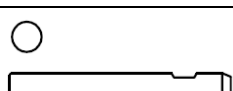
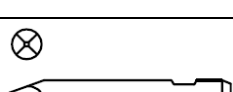
	Name	Length mm (in)	Weight kg (lb)	Diameter mm (in)	Notes
	Cone tool (A)	403(15.86)	4.2(9.3)	44.5(1.75)	
	Chisel tool (B)	403(15.86)	4.4(9.7)	44.5(1.75)	
	Blunt tool (C)	403(15.86)	4.8(10.6)	44.5(1.75)	
	Moil tool (D)	403(15.86)	4.3(9.5)	44.5(1.75)	

1.3 Structure

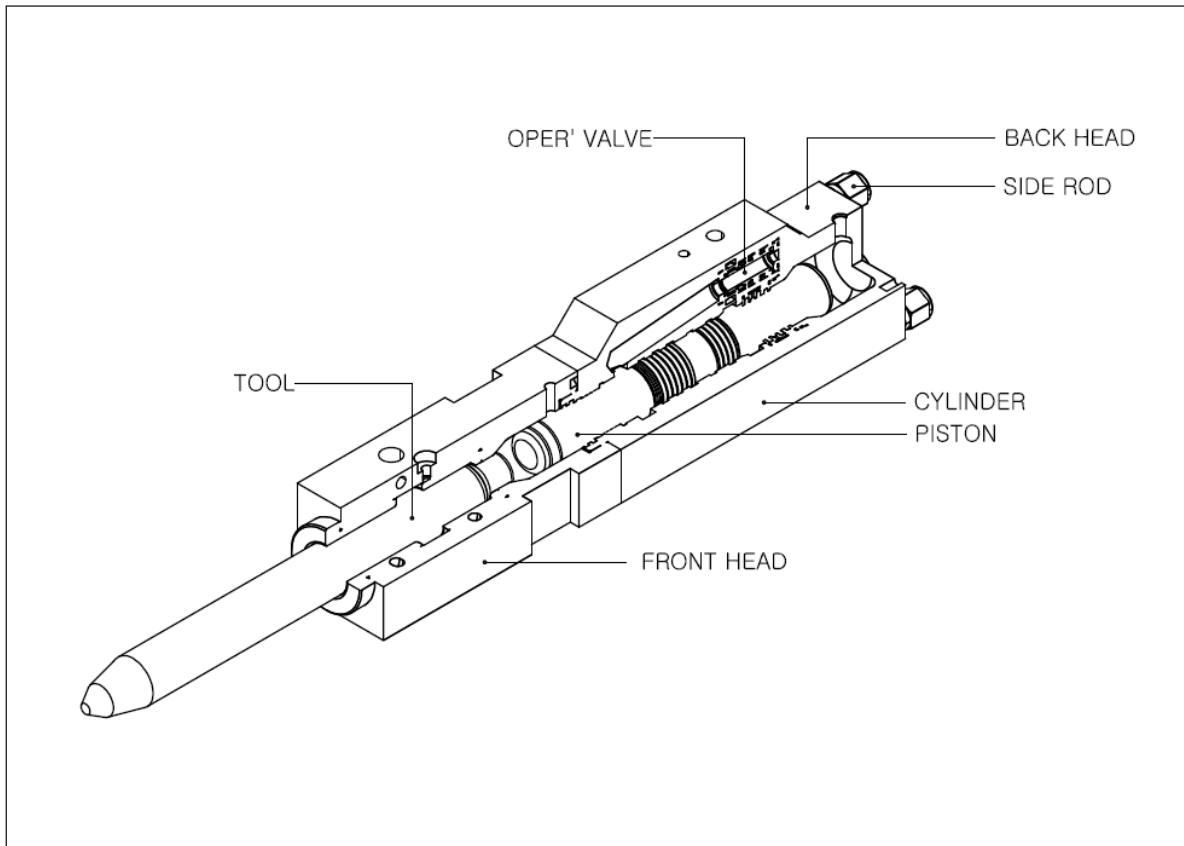

- 1) SIDE ROD
The front head, cylinder and the back head of the breaker body are secured with four side rods.
- 2) BACK HEAD
The gas charging valve is built in and charged with N^2 gas to improve the hammering power.
- 3) CONTROL VALVE
The control valve is built into the cylinder and it controls the piston's hammering action.
- 4) CYLINDER
The cylinder is the heart of the breaker body.
- 5) PISTON
The kinetic energy of the piston is converted into hammering energy when the piston hits the tool; this consequently breaks the material.
- 6) FRONT HEAD
The front head supports the entire breaker with the thrust ring and the built in upper bushing protects the carrier from the shock transmitted by the tool.
- 7) TOOL
The cone, chisel, blunt and moil tools are used for breaking different types of material.

2. Operation

2.1 Product numbers

The serial number is stamped on the back head.

It is important make correct reference to the serial number of the attachment when making repairs or ordering spare parts. Identification of the serial number is the only proper means of identifying parts for each specific unit.

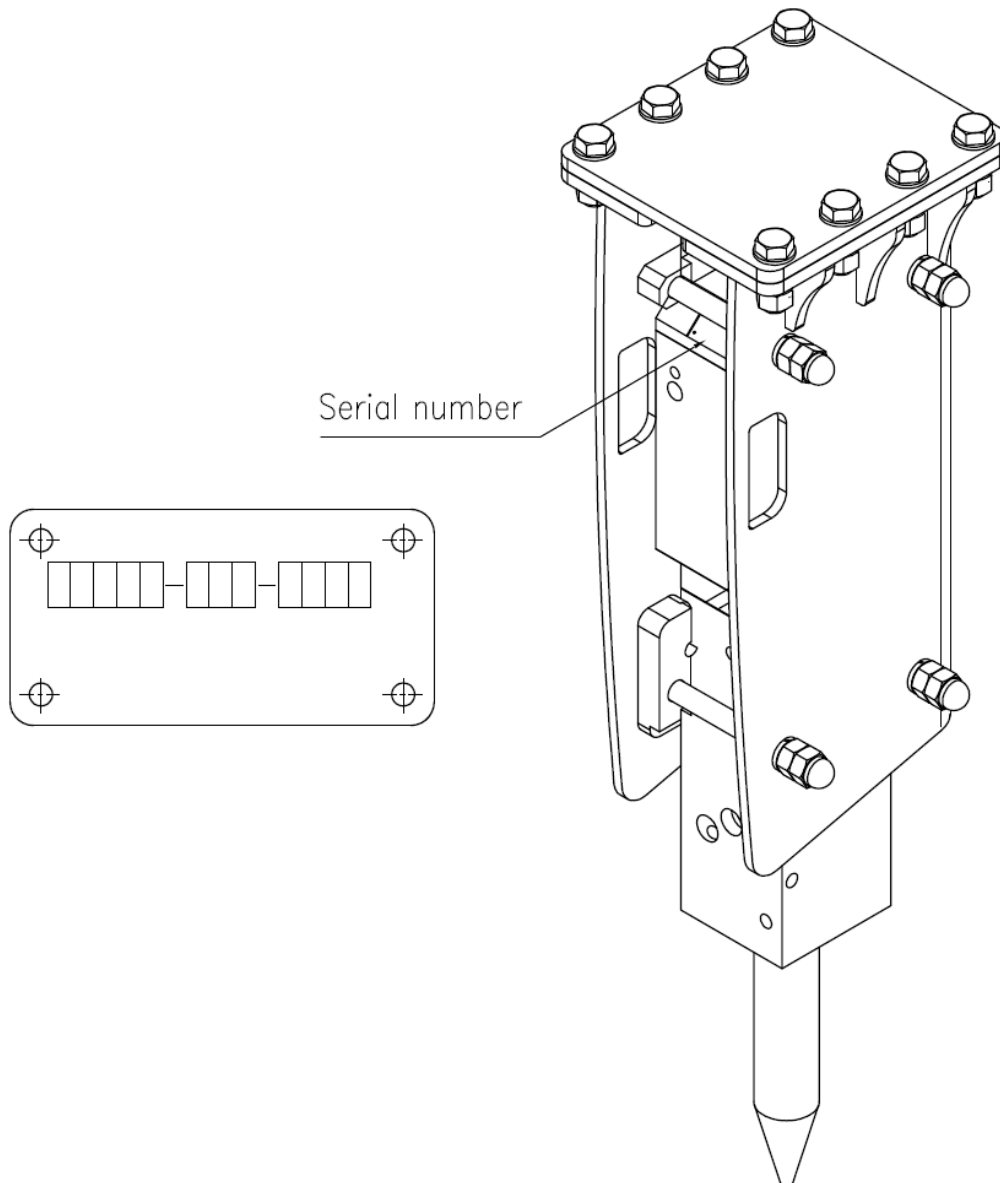

2.2 Tool Selection

Vulcan Attachments offers a wider selection of standard and special tools to suit your every need. The correct tool should be selected for each application to ensure you are getting the best possible results and the longest working life of your tool.

1) Blunt

- * For igneous (e.g. granite) and tough metamorphic rock (e.g. gneiss) into which the tool does not penetrate.
- * Concrete.
- * Boulders.

2) Chisel, cone, andmoil

- * For sedimentary (e.g. sandstone) and weak metamorphic rock into which the tool can penetrate.
- * Concrete.
- * Trenching and benching.

2.3 Breaking Principles

- * There are two general ways of breaking with a gas-type breaker.

1) Penetrative (or cutting) breaking

- * In this form of breaking the cone point or chisel tool is forced inside of the material. This method is most effective in soft, layered, low abrasive, or plastic material.

2) Impact breaking

- * In impact breaking, the material is broken by transferring very strong mechanical stress from the tool into the material.
- * The best possible energy transfer between the tool and the object is achieved with a blunt tool.
- * Impact breaking is most effective in hard, brittle and very abrasive materials.

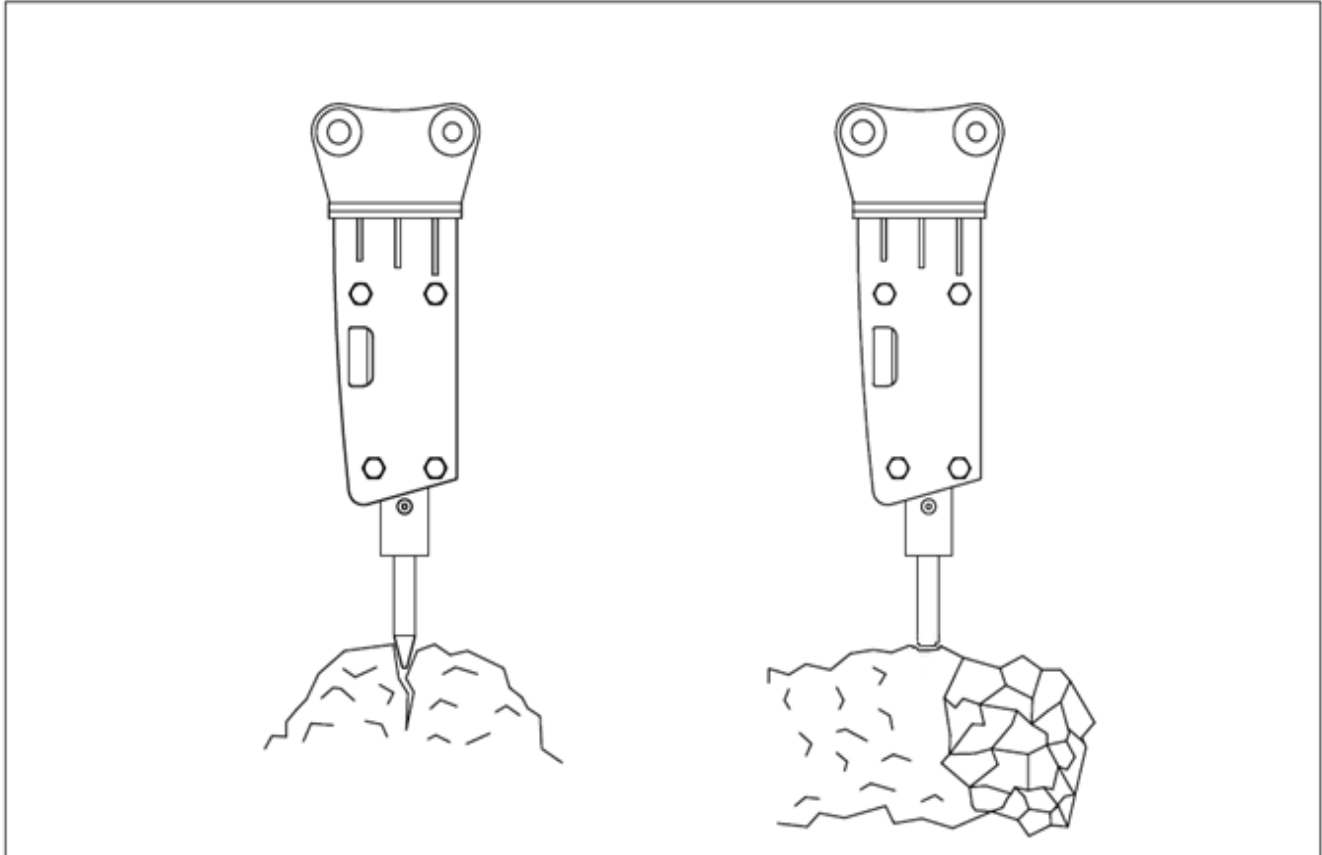

2.4 Correct working methods

- 1) Prepare the carrier as you would for normal excavation work.
 - a. Move the carrier to work location.
 - b. Engage the parking brake.
 - c. Put the carrier in neutral gear.
 - d. Disengage the boom lock (if fitted).
- 2) Set the engine speed to the recommended engine RPM.
- 3) Place the tool against the object at a 90° angle.
 - a. Avoid small irregularities on the object which will break easily and cause either idle strokes or incorrect working angles.
 - b. Incorrect working methods may cause failure in the operation of the breaker or the housing.
- 4) Use the excavator boom to press the breaker tool firmly against the object.
 - a. Do not use the breaker tool as a pry bar to pry the breaker with the boom.
 - b. Do not press down too much or too little with the boom.
- 5) Start the breaker.
- 6) Do not let the tool move outwards from the breaker when it penetrates.

* Feed the breaker at all times with the excavator boom.
- 7) Keep the tool at 90° at all times.
 - c. If the object moves or its surface breaks, correct the angle immediately.
 - d. Keep the feed force and tool aligned.

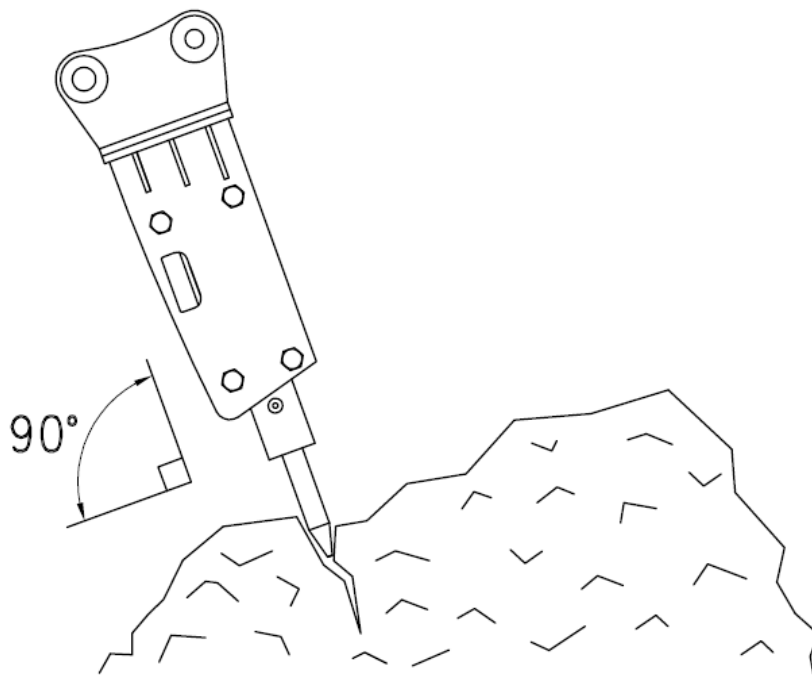

- 8) Stop the breaker quickly.
 - e. Do not allow the breaker to fall off the object or make idle strokes when the object breaks. Constant idle strokes have a deteriorating effect on the breaker.
 - f. If the breaker falls off the object, side pressure could occur, and side plates will be worn down more quickly.
- 9) Chisel, cone, andmoil
 - * If the object does not break after fifteen seconds, stop the beaker and change the position of the tool. Leaving the tool in the same position for more that fifteen seconds will only make an indentation, which will fill with dust and dampen the impact effect. This will cause the tool to overheat.
- 10) When breaking concrete, hard ground, frozen ground, or any similar material, never strike and pry with the tool at the same time. This could break the tool.

2.5 Operating Temperature

- * The operating temperature is -20°C ~ 80°C . If the temperature is lower than -20°C (-4°F), the breaker and tool must be preheated before starting to operate, in order to avoid breakage of the accumulator membrane and the tool. During operation they will remain warm.

2.6 Important Operation Points

- g. Listen to the breaker's sound while you are working.
 - * If the sound becomes thinner and the impact is less efficient, the tool is misaligned with the material and/or there is not enough "pressing" force on the tool.
 - * Realign the tool and press the tool firmly against the material.
- h. The breaker, as a standard assembly must not be used underwater.
 - * If water fills the space where the piston strikes the tool, a strong pressure wave is generated and the breaker could be damaged.

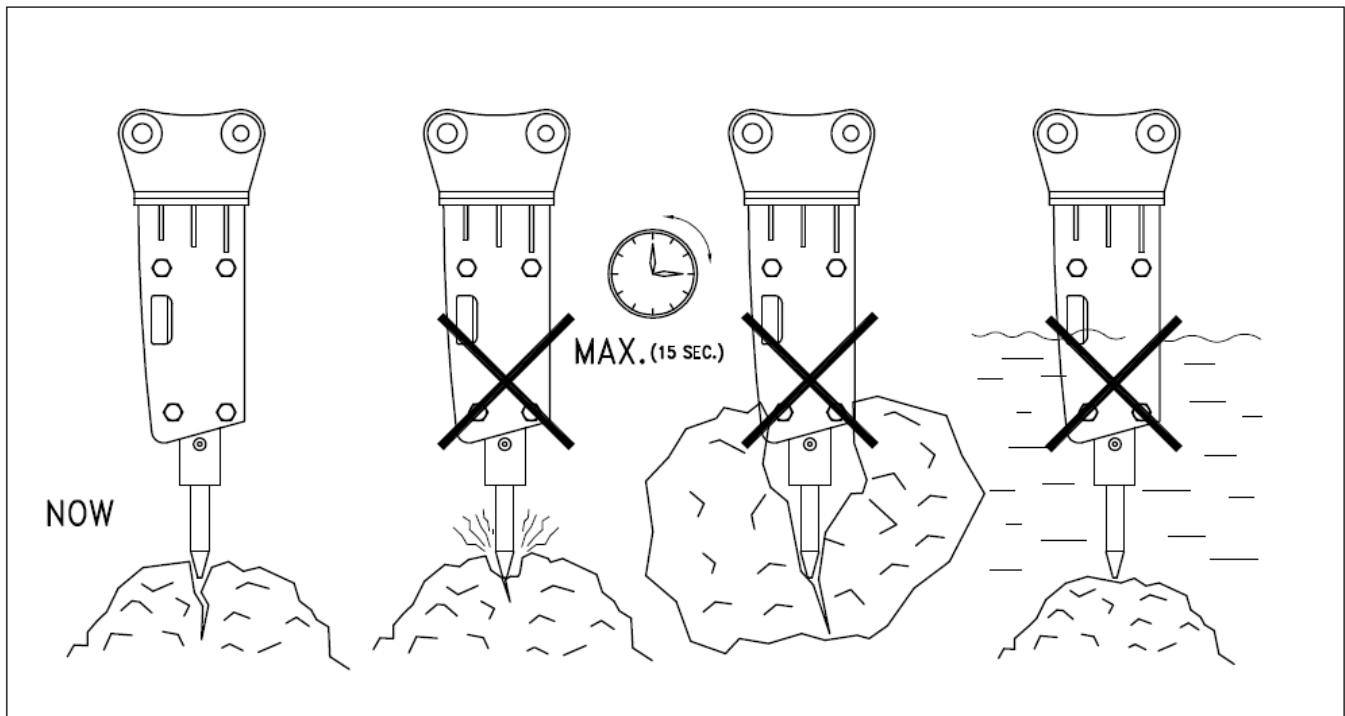

2.7 Storage

Long term storage

Observe the following points when the hammer is stored for a long period of time. This will protect the vital parts of the attachment from rusting, and keeps the breaker ready for use whenever it is needed.

1. The storage area must be dry.
2. The tool must be removed from the hammer.
3. The lower end of the piston, tool and the tool bushing must be well protected with grease.
4. Connections must be sealed with clean plugs to prevent oil leakage and dirt from getting into the couplings.
5. The breaker must be stored in the vertical position.
6. Ensure that the breaker cannot fall over.

2.8 Mounting and Dismounting the Hammer

Removal from the carrier

1. Position the hammer horizontally on the floor and remove the tool.
2. Stop the carrier engine. Operate boom and hammer controls to release the trapped pressure inside of the hoses. Wait ten minutes for the oil pressure to drop.
3. Close the hammer inlet and outlet lines. If quick couplers are used, disconnection automatically closes the hammer lines.
4. Disconnect the hoses and plug them as well as the hammer inlet and outlet ports.
5. Remove the bucket pins and other parts.
6. The carrier can now be moved aside.

Installation

1. Install the hammer in the same manner as mounting a bucket, install bucket pins.
2. Connect the hoses. Hammer inlet port is marked on the back head with "IN" and the outlet port is marked with "OUT".
3. Open the hammer inlet and outlet lines.

WARNING!

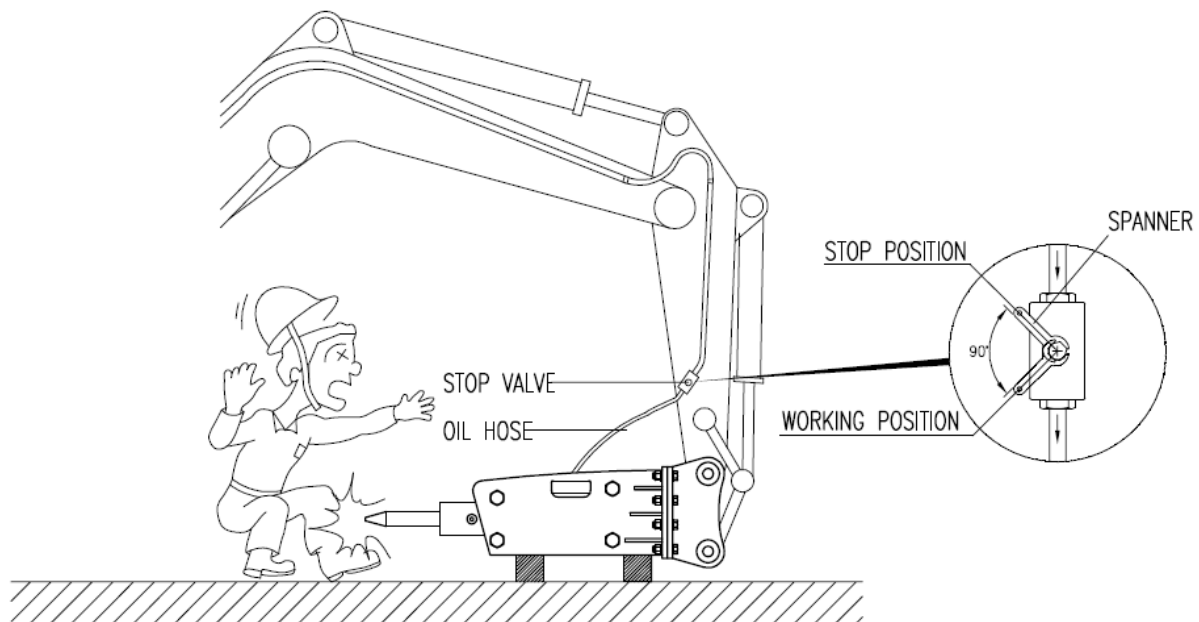

2.9 Operation Pressure Settings

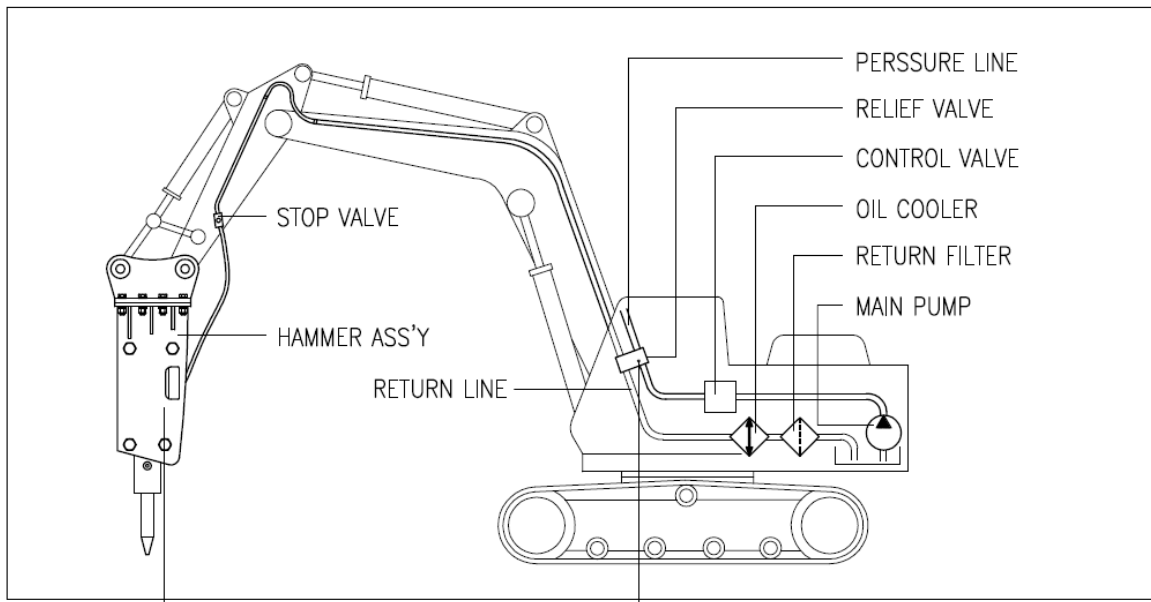

Model	Operating Pressure
VULCAN V2G	90 ~ 120 bar

Model	Relief Pressure
VULCAN V2G	140 ~ 160 bar

1) Operating Pressure

- a. Stop the carrier engine.
- b. Assemble the high pressure gauge to the high pressure test port. Start the engine.
- c. Set the tool of the breaker on something stable (e.g. a thick steel plate).
- d. Adjust the operating engine revolution and start to operate the breaker.
- e. Read the average pressure from the high pressure gauge.
- f. Operating pressure is pre-adjusted at the factory and there should be no reason to adjust it.
- g. Stop the carrier and remove the gauge.
- h. Tighten the plug of the pressure measuring point.

2) Relief Valve

- a. The relief valve is a safety device which is used to protect the breaker when the pressure rises in the hydraulic circuit.
- b. The operating pressure of the breaker determines the setting of the relief valve in the pressure line.
- c. The relief valve setting should be adjusted to the specifications of each Vulcan model.

2.10 Hose and Pipe Specification

Model	Hose Assembly		Piping Line Size		Notes
	IN	OUT	IN	OUT	
V2G	PF 1/2"	PF 1/2"	PF 1/2"	PF 1/2"	

2.11 Hydraulic Circuit

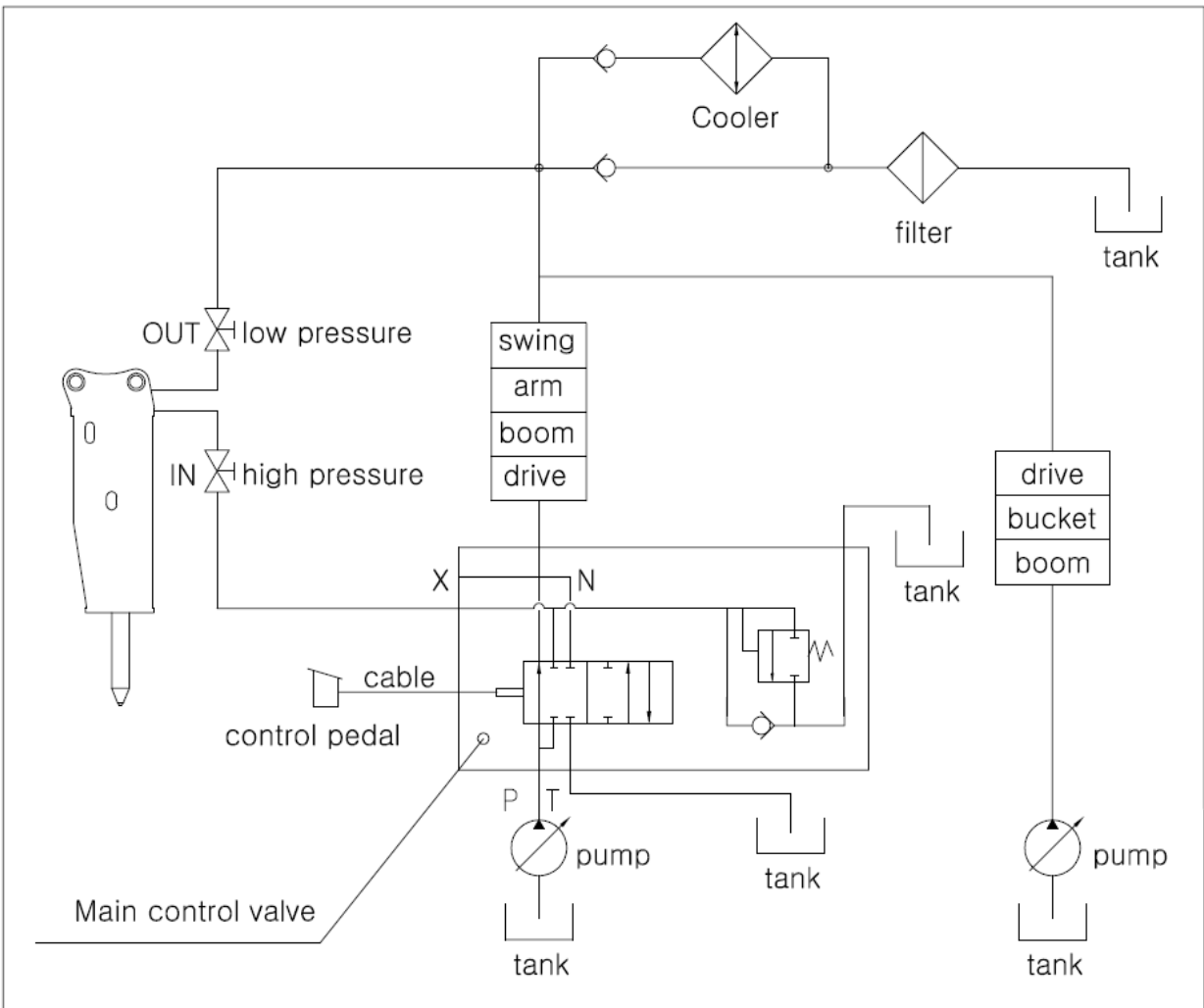

3. Lubrication

3.1 Manual Lubrication

* Grease interval

1. The tool shank and tool bushing must be well lubricated before installing the tool.
2. Apply 10 – 20 strokes from the grease gun to the tool bushing and the tool at regular intervals.
3. Adapt the interval and amount of grease to minimize tool wear and keep it in good working condition.

Greasing should be done every hour.

Insufficient greasing or improper grease could cause:

- Abnormal wear of the tool bushing and the tool.
- Tool breakage.

Technical data:

- NLGI grade 2.
- Synthetic oil base with aluminum complex soap.
- Approximately 15% graphite copper solids to reduce metal to metal contact damage.
- Dropping point 260°C (500°F).
- Viscosity 15 cSt.
- Temperature range -30° ~ 230°C (-20°F ~ 450°F).

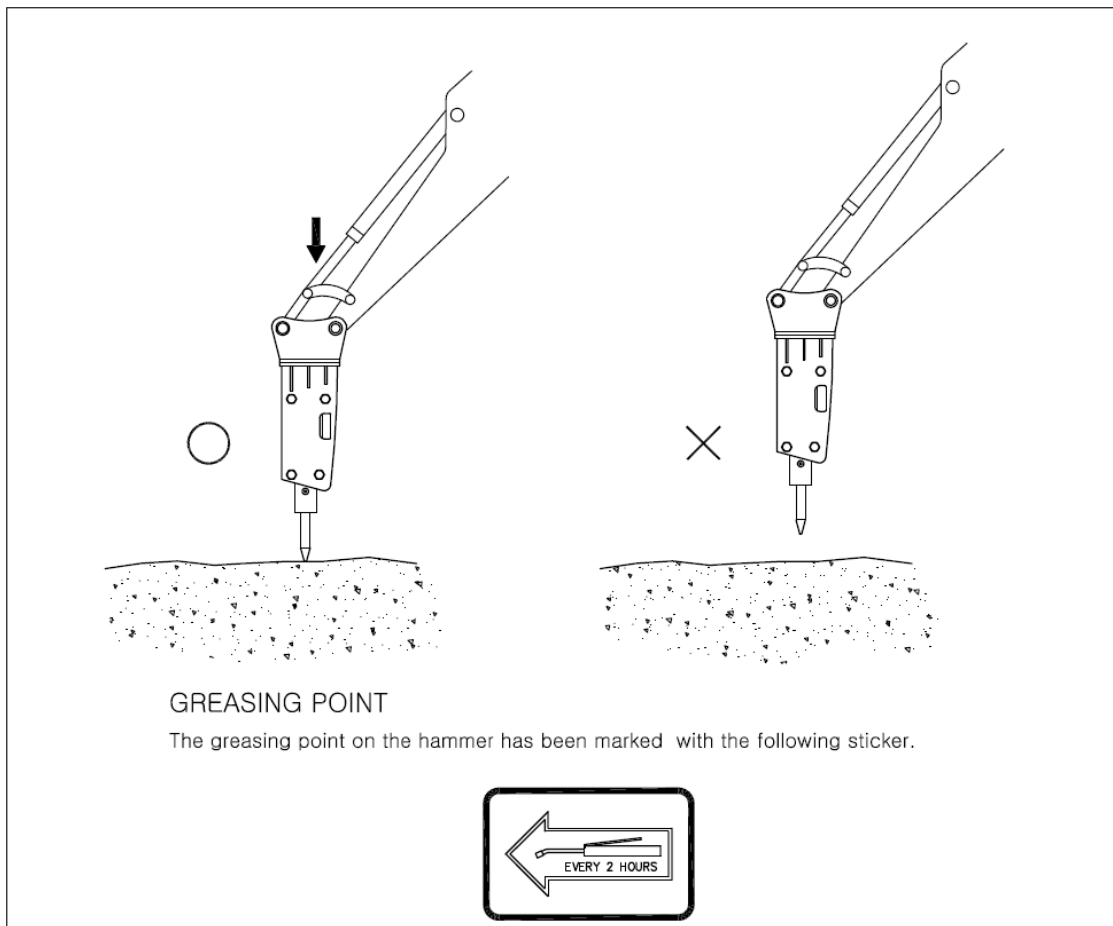

3.2 Hydraulic Oil

- * When the breaker is used continuously, the temperature of the hydraulic oil normalizes at a certain level, depending on the conditions and the carrier. At this temperature, the viscosity of the hydraulic oil should be 20 ~ 30 cSt (2.90~5.35°E).
- * The Vulcan hydraulic breaker must not be started if the viscosity of the hydraulic oil is above 1000 cSt (131°E) or operated when the viscosity of the hydraulic oil is below 15 cSt (5.35°E).

1) When the oil is too thick, the following problems may occur.

- a. Difficulty starting.
- b. Stiff operation.
- c. Irregularly and slow striking.
- d. Danger of cavitations in the pumps and hydraulic breaker.
- e. Sticky valves.
- f. Filter bypass, impurities in the oil not removed.

2) When the oil is too thin, the following problems may occur.

- a. Efficiency losses (internal leaks).
- b. Damage to gaskets and seal leaks.
- c. Accelerated wearing of parts, caused by decreased lubrication efficiency.

3) Special oils

- * In some cases special oils (e.g. biological oils and non-flammable oil) can be used. Please observe following aspects when considering the use of special oil:
 - * The viscosity range in the special oil must be within the range of 15 ~ 1000cSt (2.35~131°E).

* Recommended Oil, Temperature, Viscosity

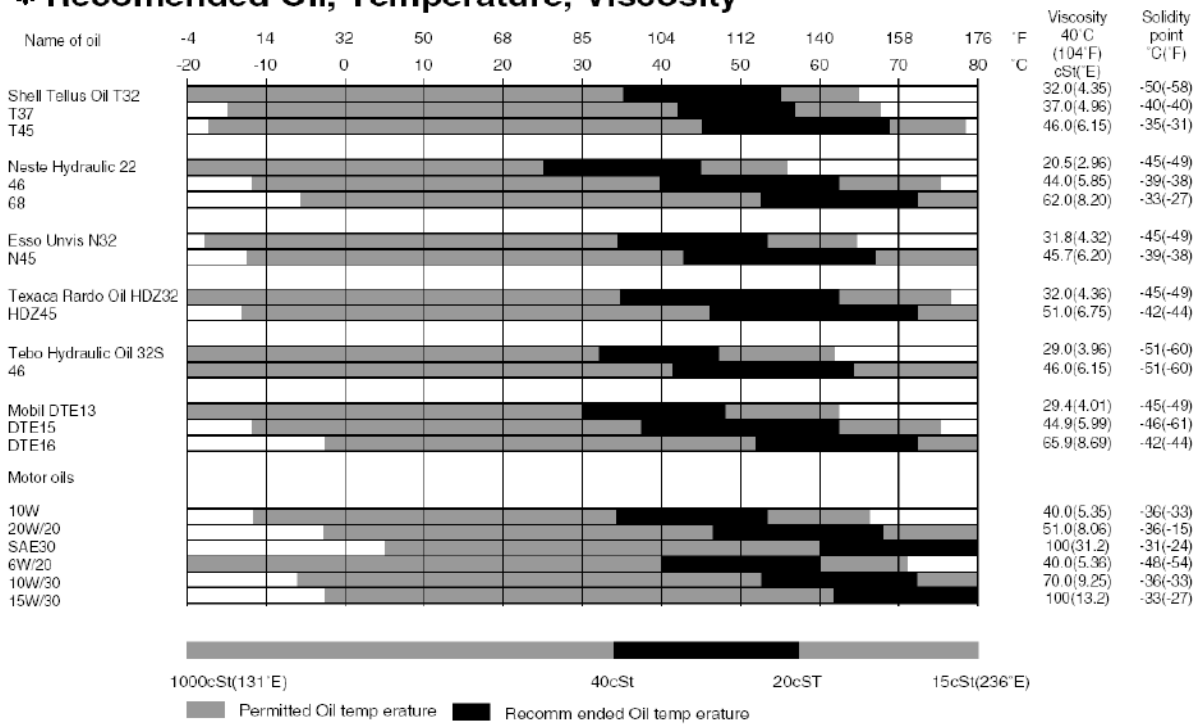

- 4) Cleanliness of the hydraulic oil
 - * The hydraulic oil filter of the carrier will clean the oil flowing through the breaker.
 - * The purpose of the oil filter is to remove impurities from the hydraulic oil since they accelerate component wear, cause blockages and even seizure.
 - * Impurities also cause the oil to overheat and deteriorate.
 - * Air and water are impurities in oil.
- 5) Oil filter
 - * When working with the hydraulic breaker, the carrier oil filter must fulfill the following specifications:
 - a. The oil filter must be rated at 25 microns maximum.
 - b. The oil filter must be a standard return line filter rated to maximum working pressure.
 - c. The oil filter must have a volume flow capacity of at least twice the breaker's maximum flow.
 - d. The cooler must withstand a dynamic pressure of 290 psi (20 bar).
- 6) If the carrier's oil cooler is too small, the original cooler must be replaced with a larger one or an auxiliary cooler must be installed. The auxiliary hydraulic cooler can be installed:
 - a. In front of the radiator, in which case an additional fan is not required, i.e. maximum rise of cooling air is 5°C (40°F).
 - b. Any other suitable place, using a fan either hydraulically or electrically driven
- 7) Damage caused by hydraulic oil contamination in the carrier and breaker circuits causes:
 - a. The working life of the pumps to be significantly shortened.
 - Premature wear of the parts.
 - Cavitation.
 - b. Valves to not function properly.
 - Spools bind – premature wear of the parts.
 - Blocking of small holes.
 - c. Wear of the cylinders.
 - d. Reduced breaker efficiency.
 - Premature wear of moving parts and seals.
 - Danger of the piston seizing and the oil overheating.
 - e. Shortened working life and reduced efficiency of hydraulic oil.
 - Oil overheats and the oil quality deteriorates.
 - Electro-chemical changes in the hydraulic oil.

4. Maintenance

4.1 Removal and Installation of Tools and Tool Bushings

1) Removal

- a. Place the breaker on level ground.
 - b. Make sure that the carrier's transmission is in neutral and the parking brake is engaged.
 - c. Stop the engine.
 - d. Push the spring pin A as far as it will go.
 - e. Remove the tool pin B
 - f. Remove the tool.
 - g. Remove the tool bushing C.
- Check the tool and the tool bushing for wear.

2) Installation

- a. Clean all parts
- b. Apply MoS₂ spray to the contact surfaces of the tool holder bushing and front head.
- c. Install the tool bushing C.
- d. Install the tool pin B.
- e. Install the tool and spring A.

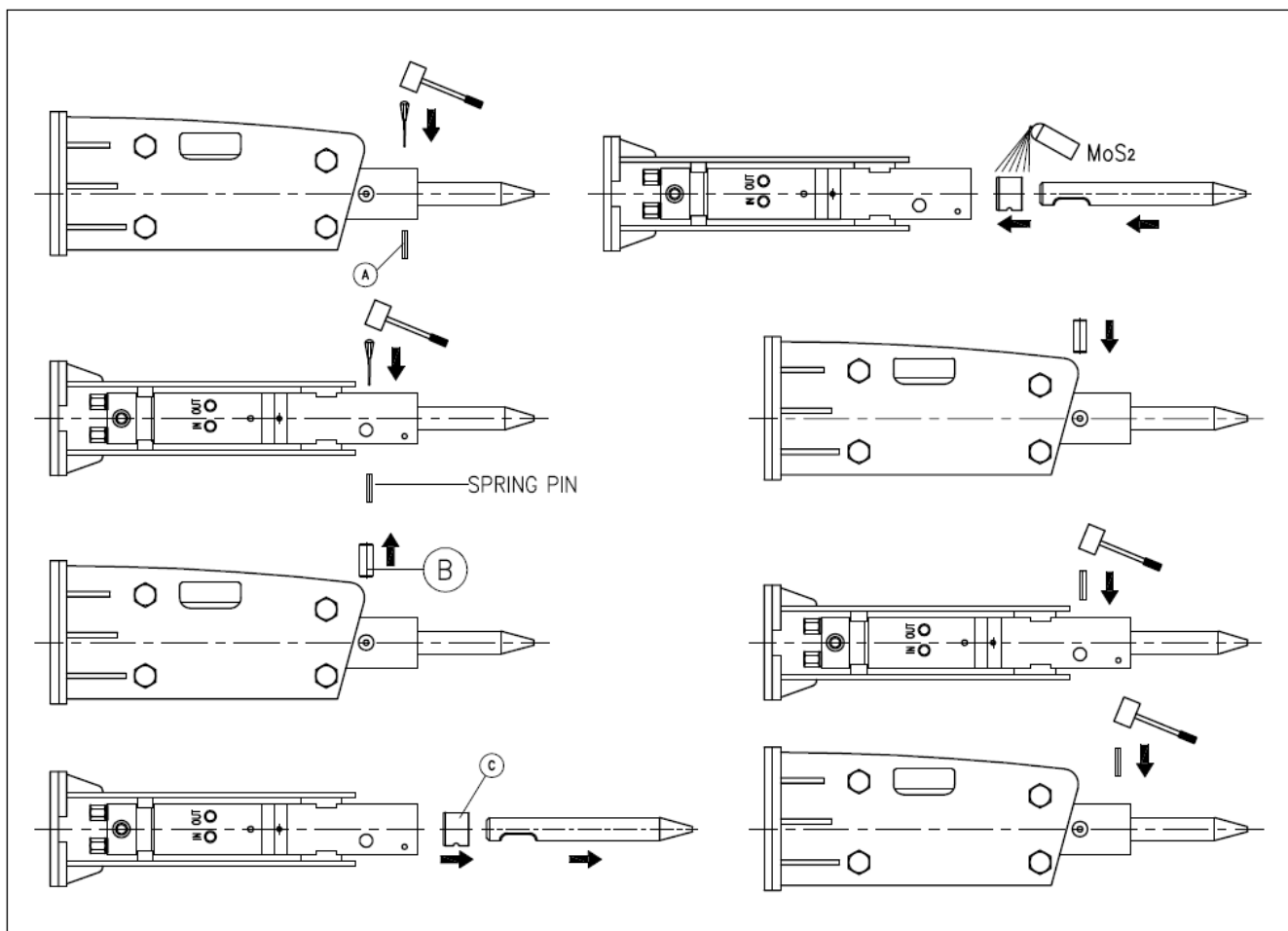

4.2 Wear Limits of Tools and Tool Bushings

- 1) The normal clearance between the tool and the tool bushing is 4mm.
Check the wearing condition of the tool bushing and replace with a new tool bushing if clearance is out of the specified range.
- 2) The tool bushing can be used continuously unless serious wear is found.

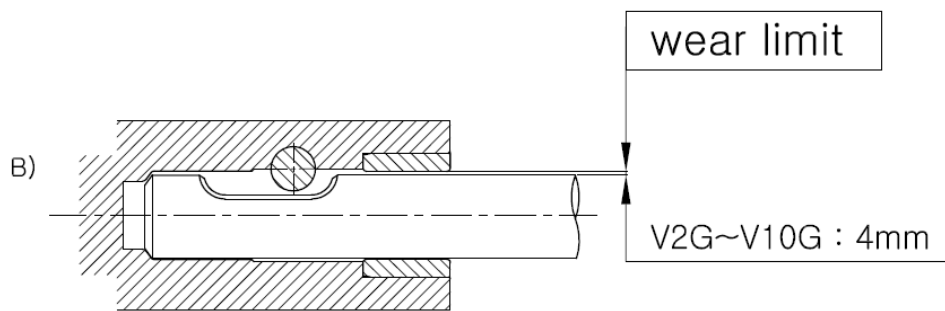
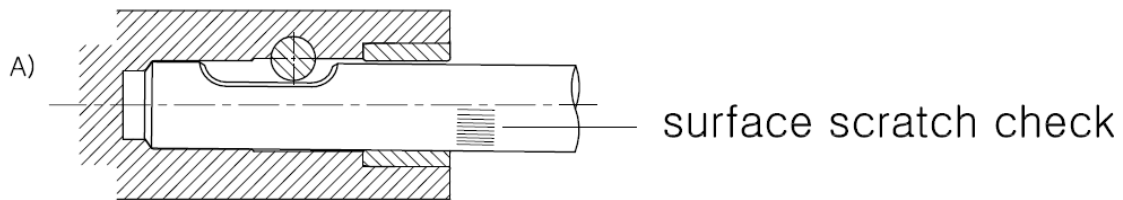

C) Standard Inside Diameter of the TOOL BUSHING and TOOL

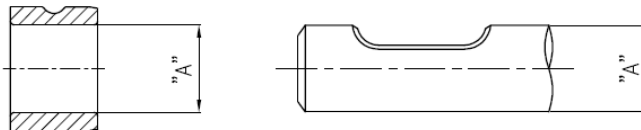

Model	Parts Name	New	Reject	Notes
V2G	Tool Bushing	44.5 mm	46.5 mm	
	Tool	44.5 mm	42.5 mm	

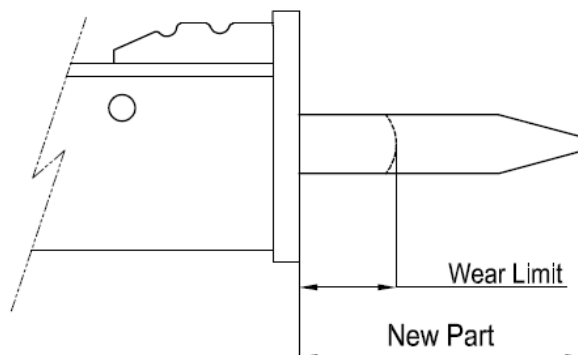

Model	New	Reject
V2G	188	150 mm

4.3 Disassembling and Assembling the Hammer Assembly

1) Disassembling

- a. Remove the tool and set the breaker down vertically on the floor.
- b. Disconnect the hoses and plug them and the breaker inlet and outlet ports with clean plugs.
- c. Loosen the mounting bracket bolt B, lock washer C, and nut D to remove the mounting bracket A from the breaker.
- d. Remove the front head joint bolt E, and washer F.
- e. Remove the side brackets.

2) Assembling

- a. Set the breaker down vertically on the floor.
- b. Install the side brackets.
- c. Install the washer, cap nut and housing bolts.
- d. Connect the mounting bracket by tightening the mounting bracket bolts.
- e. Remove the plugs from the hoses and connect them to the breaker's inlet and outlet ports.
- f. Connect the pressure and return lines.

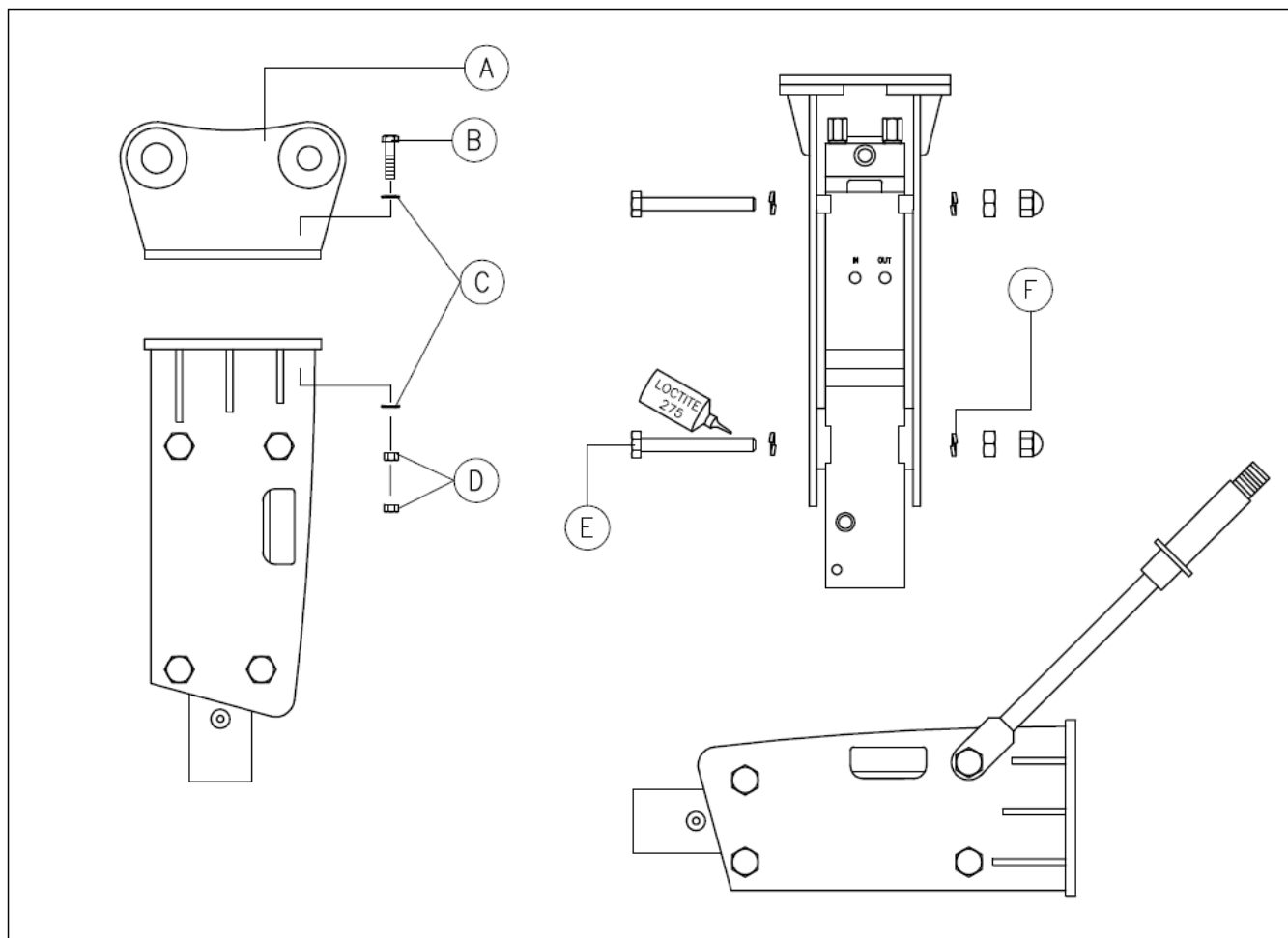

4.4 Disassembling and Assembling the Back Head

- 1) To Release the pressure from the back head:
 - a. Remove the side bracket from the breaker.
 - b. Fix the hammer assembly into the assembly stand D by lifting the hammer assembly with lift ring A.
 - c. Remove lift ring A.
 - d. Open the gas plug C carefully. To release the nitrogen gas put a pin, smaller than 7mm in diameter, into the charging valve.
 - e. If you do not understand this procedure please contact your local dealer.

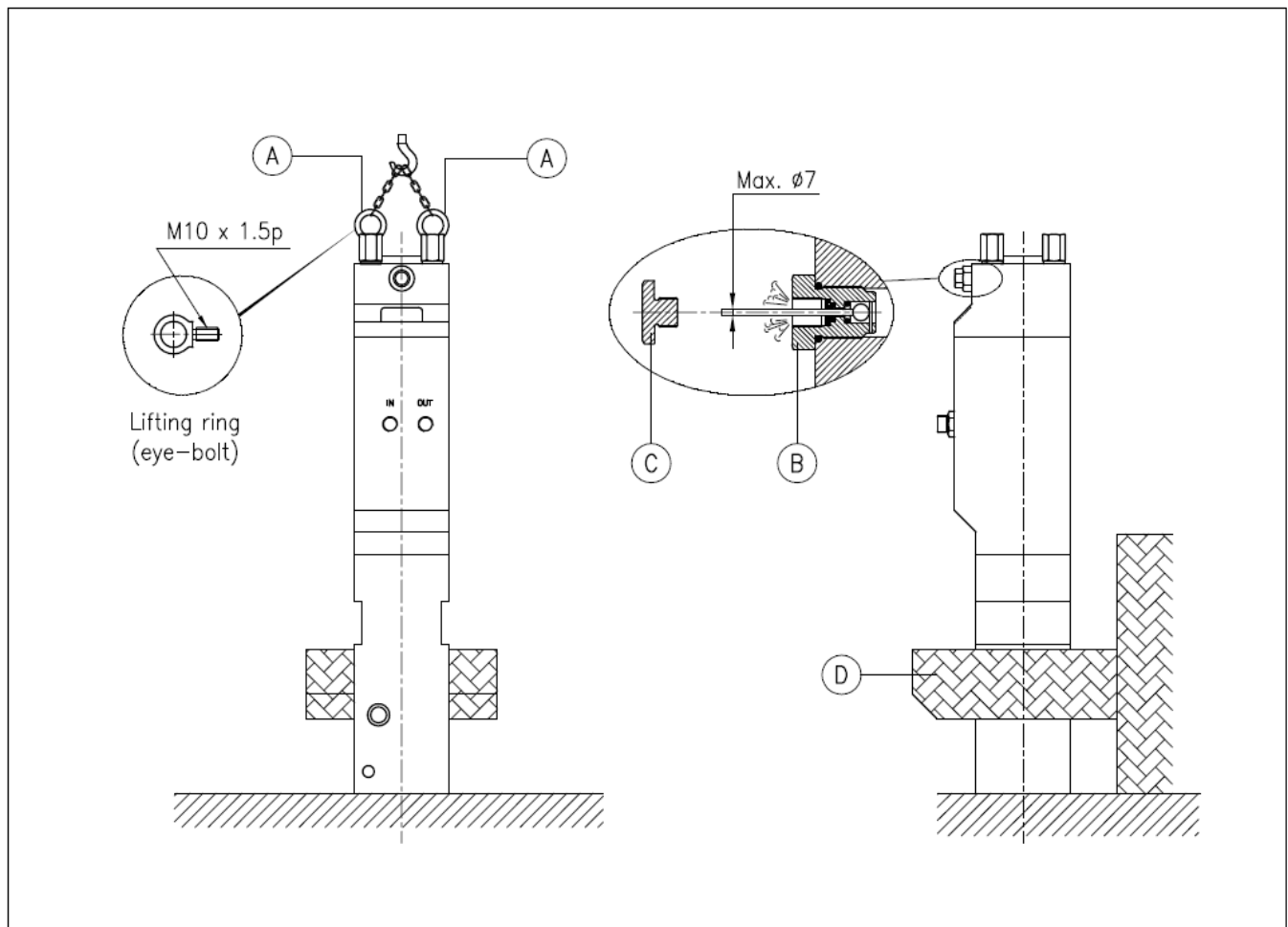

2) Removal

- a. Loosen side rod nut A and washer B.
- b. Remove side rod C.
- c. Lift the back head D from the hammer assembly.

3) Assembling

- a. Clean and dry each part carefully.
- b. Apply some thread grease to the thread area on the side rod C.
- c. Install the side rod, washer and nut.
- d. Tighten the side rod nut to the specified torque value with a torque wrench.

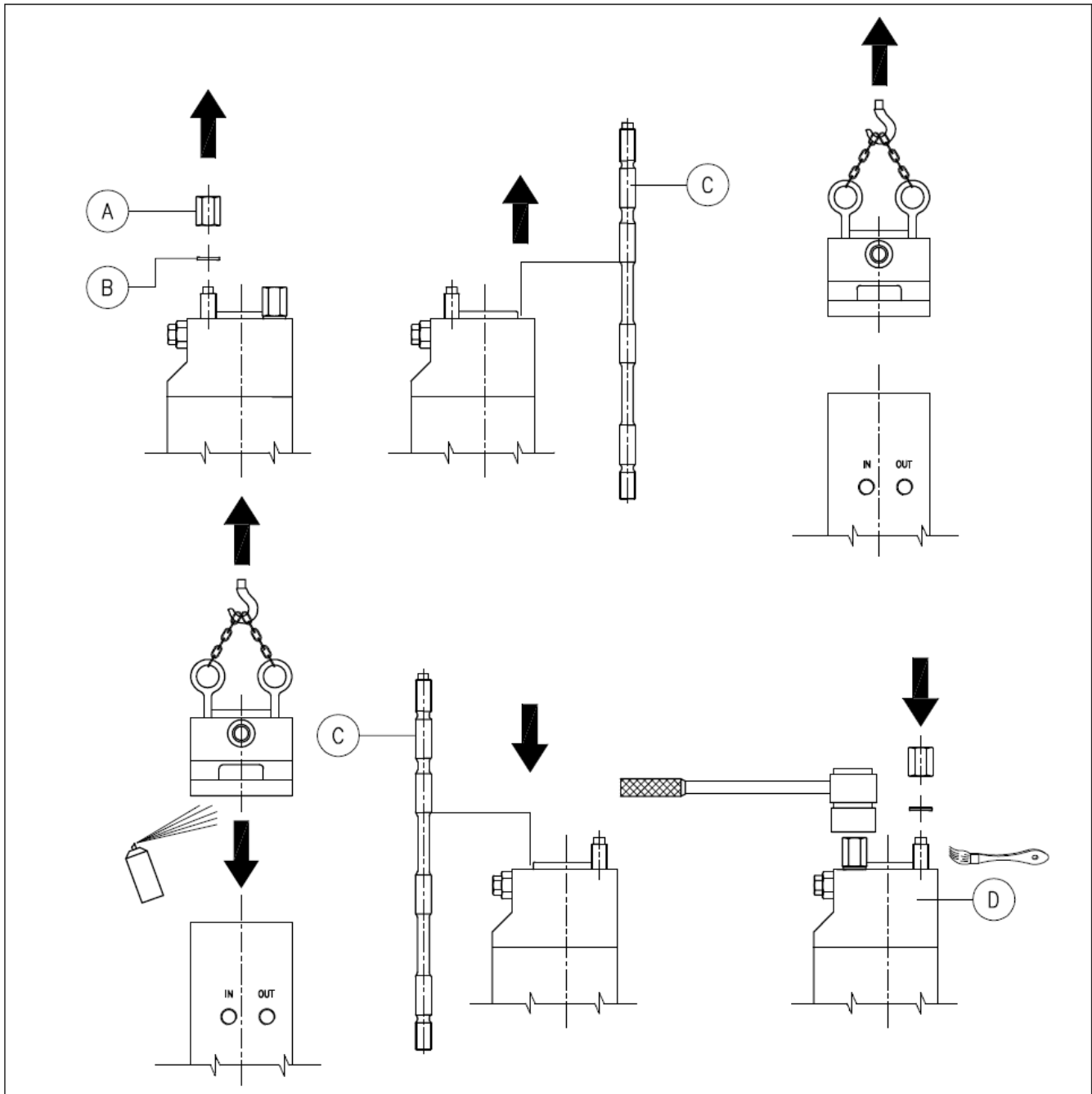

4.5 Nitrogen gas charging device and method

- 1) Setting the Nitrogen gas pressure method
 - a. Loosen the gas plug on the back head by using the 5mm L-wrench.
 - b. Connect the charging kit to the gas charging valve on the back head
 - c. Pull the pusher of the charging kit up.
 - d. Close the screw valve.
 - e. Charge to the pressure shown in column A by opening the valve of the nitrogen bottle.

- 2) Setting the Nitrogen gas pressure
 - a. Close the valve of the nitrogen bottle, and wait 2 minutes for the pressure to stabilize.
 - b. Adjust the pressure to that shown in column B by adjusting the pusher and the control screw valve.
 - c. Pull up the pusher of the charging kit and remove it.
 - d. Tighten the gas plug.

Model	A	B
V2G	20 bar (290 psi)	16 bar (230 psi)

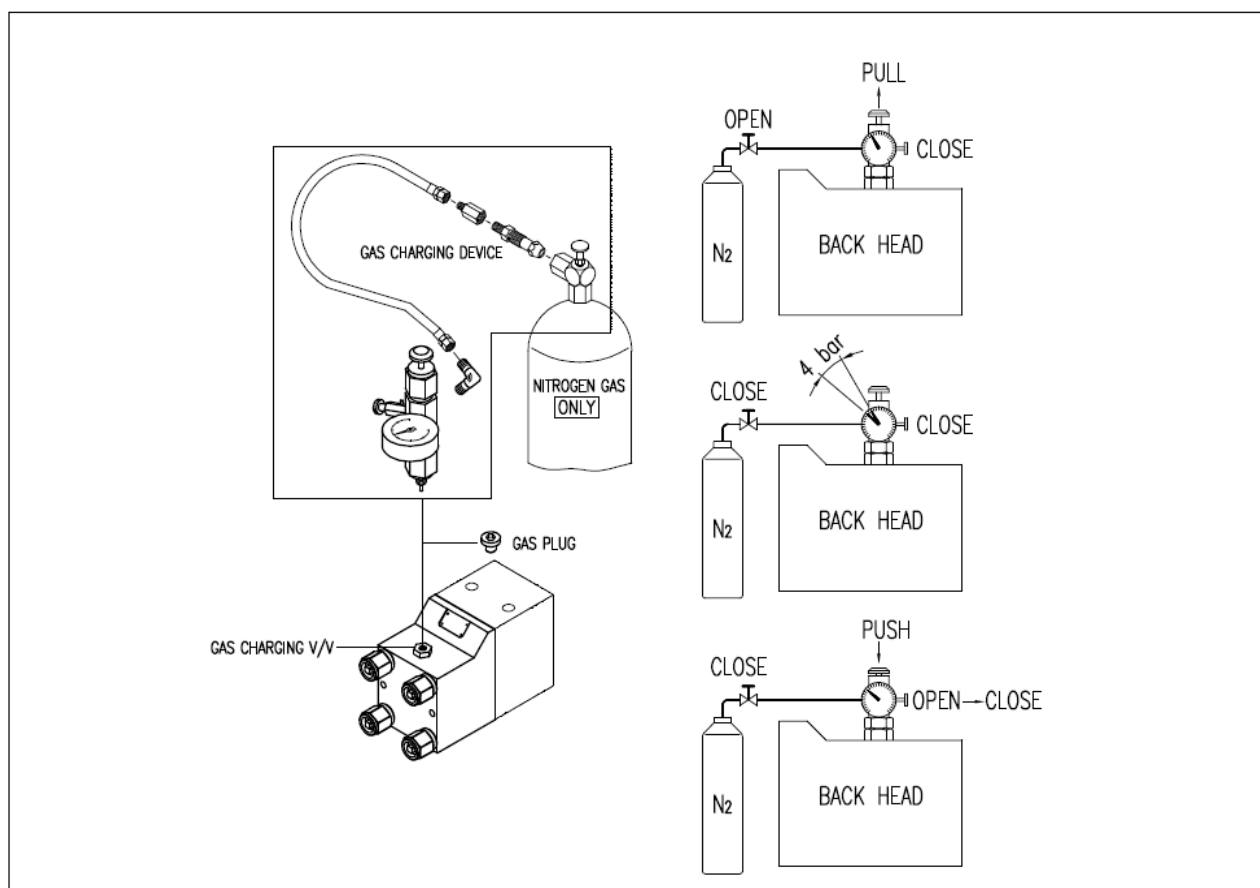

4.6 Loosening and tightening side rods

1) Loosening

- a. Remove the side rod nut and washer.
- b. Remove the side rod with a spanner.

2) Tightening

- a. Check for cracks on the side rods, if there are cracks, replace.
- b. Clean and grease the side rods.
- c. Tighten the side rods using a spanner. Ensure they are tight enough not to come out.
- d. Tighten the side rod nut to the specified torque with a torque wrench.

Hydraulic Hammer Side Rod Tightening Torque		
Model/Torque(N.M.)	1st	2nd
V2G	200	300

Side Rod Nut Hexagon Socket Size	
Model	Size
V2G	27mm

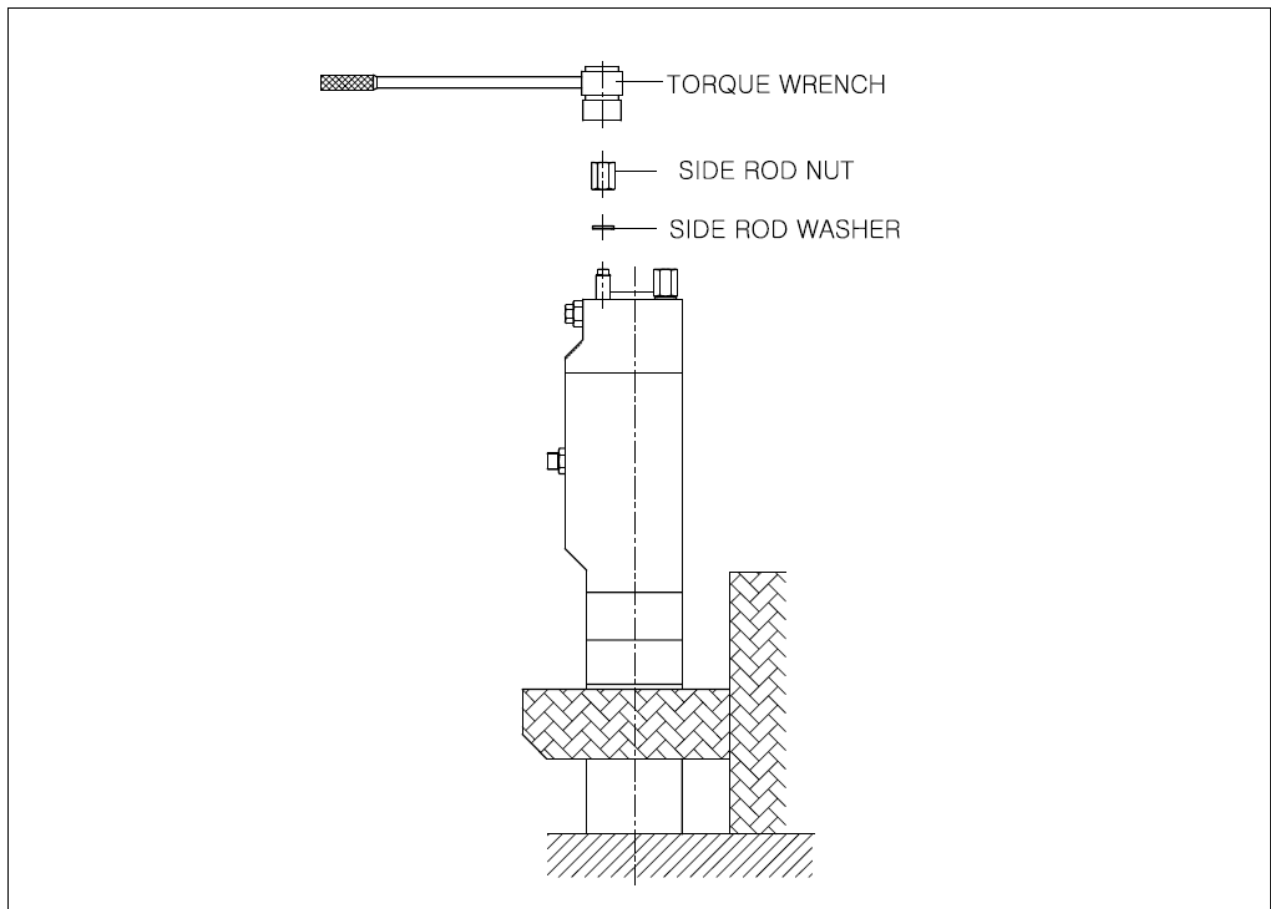

4.7 Torques

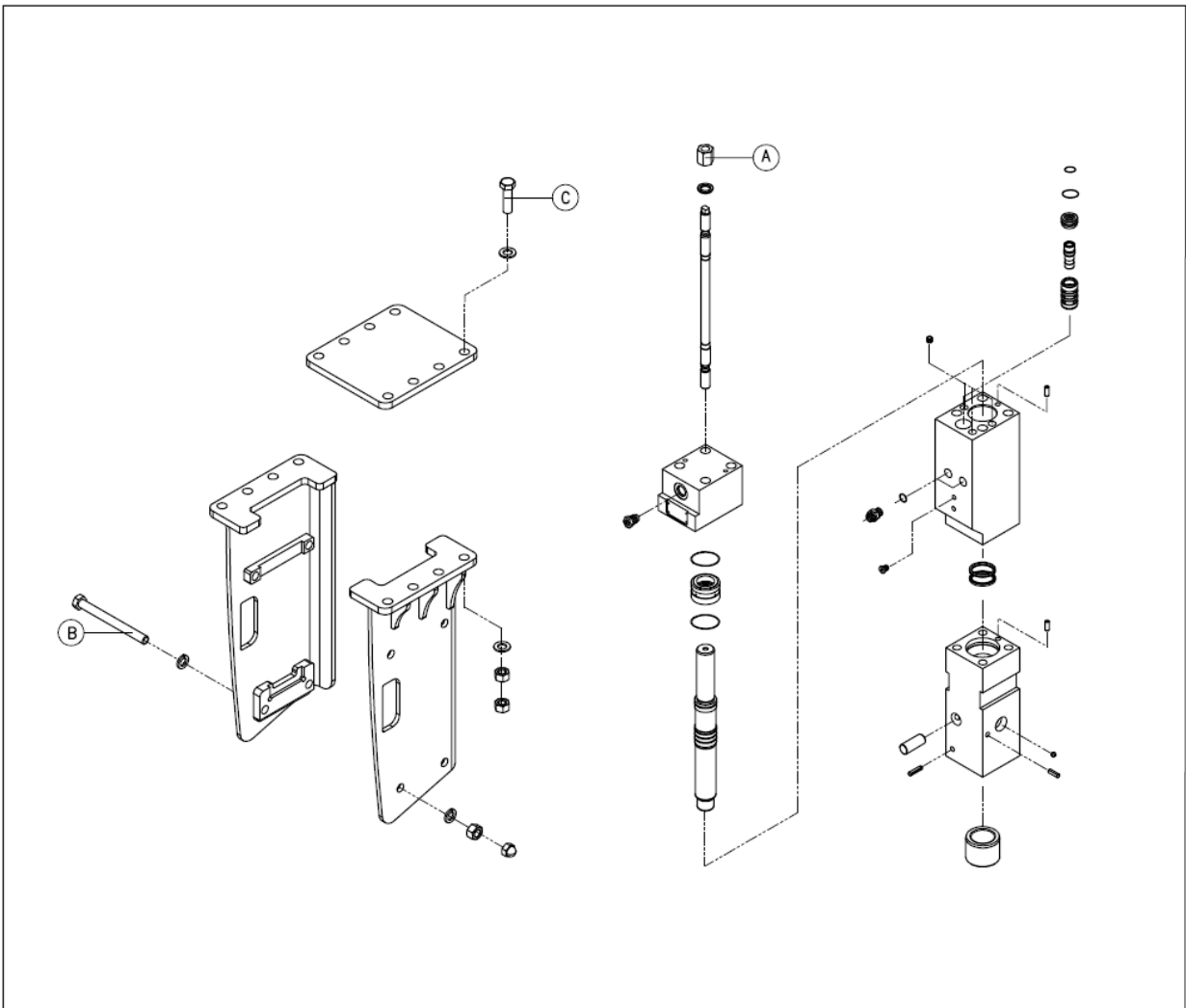

Item	N.m	kg.m	ft.lb	Description	Q'ty
A	300	30	220	Side Rod Nut	4
B	300	30	220	Housing Joint Bolt	4
C	300	30	220	Top Cover Bolt	8

4.9 Workshop tool

No.	Part Name	Specifications	Q'ty	Note
1	Tool Box	Small Size	1	
2	Single Spanner	24mm		Air Breather
3	Single Spanner	27mm		Side Rod, Gas Charging v/v
4	Single Spanner	30mm		Adapter
5	L - Wrench	5mm		Gas Charging v/v Plug
6	L - Wrench	6mm		¼" Plug
7	Driver (+)		1	
8	Driver (-)		1	
9	Installation Card		2 set	
10	Warranty Claim Report		2 set	
11	Hammer Card		1 set	
12	Gas Charging Kit		1 set	Optional Part
13	Gas Cylinder		3.4 liters	Optional Part
14	Seal Kit		1 set	Optional Part

5. Troubleshooting Guide

5.1 Oil leakage

Probable Cause	Remedy
a. Oil leakage between the tool and the tool bushing.	- Replace the damaged seals.
b. Oil leakage on the surface of the breaker.	- Retighten the loose breaker hoses and bolts.
c. Oil leakages on the valve block and bolts.	- This is normal, during assembly lubrication and anti-rust oil is applied.
d. Oil leakage between the cylinder and the back head.	- Tighten to specified torque.

5.2 Irregular blows after normal beginning

Probable Cause	Remedy
a. Oil temperature increased due to lack of hydraulic oil.	- Supplement the hydraulic oil.
b. Pressure in the back head is too high.	- Check the gas pressure.
c. Relief valve is set too low.	- Check the pressure of the relief valve.
d. Not enough down pressure on the tool.	- Apply enough down pressure with the arm or the boom of the carrier.
e. The clearance between the tool and the tool bushing is too large.	- Check the clearance between the tool and the tool bushing.
f. Wear on the top of the tool.	- Disassemble the tool and check.
g. Poor performance of the hydraulic pump and the back pressure is too high.	- Have the excavator manufacturer check the hydraulic piping.
h. Foreign material in the side valve.	- Disassemble and clean.
i. Seizure of the piston and cylinder.	- Overhaul and check.

5.3 No Impact

Probable Cause	Remedy
a. Oil temperature is too low.	- Oil temperature must reach a minimum of 30°C.
b. Valve does not operate properly	- Check the breaker operating button in the cabin.
c. Pressure in the back head and setting pressure of the relief valve is too low.	- Check the pressure of the nitrogen gas and the relief valve.
d. Poor performance of the hydraulic pump	- Contact the excavator manufacturer.
e. Gas pressure is too low or too high.	- Check the gas pressure.
f. Not enough down pressure on the tool.	- Apply enough down pressure with the arm or boom of the excavator.
g. Setting pressure of the relief valve is too low.	- Check the pressure of the relief valve.
h. Poor performance of the hydraulic pump.	- Check the relief valve on the excavator.
i. Hydraulic oil operating pressure is too low.	- Check the setting pressure.
j. Malfunction of hydraulic quick couplers.	- Check to ensure that the oil is flowing through the quick couplers. If it is not repair or replace malfunctioning couplers.
k. Couplers are not fully engaged.	- Connect couplers securely.

6. Generals and Safety information

6.1 General

Do not use or install the breaker until you can use the carrier. Do not rush the learning process. Take your time and learn how to operate the breaker safely and efficiently.

- * If there is anything you do not understand, ask your Vulcan service center for advice.
- * The breaker serial number is stamped on a metal plate which is located on the back head near the inlet connection.
- * Correct reference to the serial number of the breaker is important when ordering spare parts. Identifying parts for specific breaker's is only possible through the serial number.

6.2 Safety

1) Manuals

- a. Read this manual before installing, operating, or maintaining the breaker. If there is anything that you do not understand ask your employer or your local Vulcan dealer.
- b. Keep this manual in good condition for future reference.

2) Clothing

- a. Proper clothing is important to prevent injury. Loose clothing can get caught in the machinery and cause bodily harm.

3) Work site

- a. Inspect the working site before starting work.
- b. Check for potholes, weak ground, hidden rocks etc.
- c. Check for utilities like water pipes, power lines, and gas lines.

4) Metal splinters

- a. Injury can be caused by flying splinters when driving metal pins in and out.
- b. Always wear safety glasses.

5) Accumulator

- a. The accumulator is pressurized even when there is no hydraulic pressure in the breaker.
- b. Attempting to dismantle the accumulator without first releasing the pressure can cause serious injury.
- c. Do not try to dismantle the pressure accumulator, contact your Vulcan service center first.

6) Hydraulic pressure

- a. Hydraulic fluid at system pressure is very dangerous.
- b. Before disconnecting or connecting the hydraulic hoses, stop the carrier engine and operate the controls to release the pressure trapped in the hoses.
- c. Keep all personnel away from the hydraulic hoses during breaker operation.

- Regulation –

- * Observe all of the laws, work site and local regulations which affect you and your equipment.

- Practice –

- * Carrying out unfamiliar actions without practice could cause serious injury to the operator and any others on site.
- * Practice away from the job site in a clear area.
- * Keep other people away.
- * Do not perform new operations until you are confident you can carry them out safely.

- Equipment condition –

- * Defective equipment can cause injury to yourself and others. Do not operate equipment that is defective or has missing parts.
- * Make sure that the maintenance procedures in this manual are completed before operation.

- Equipment limits –

- * Operating the equipment beyond it' design limits can cause damage and be hazardous.
- * Do not operate the equipment beyond its limits.

7. Parts List

7.1 V2GS Housing

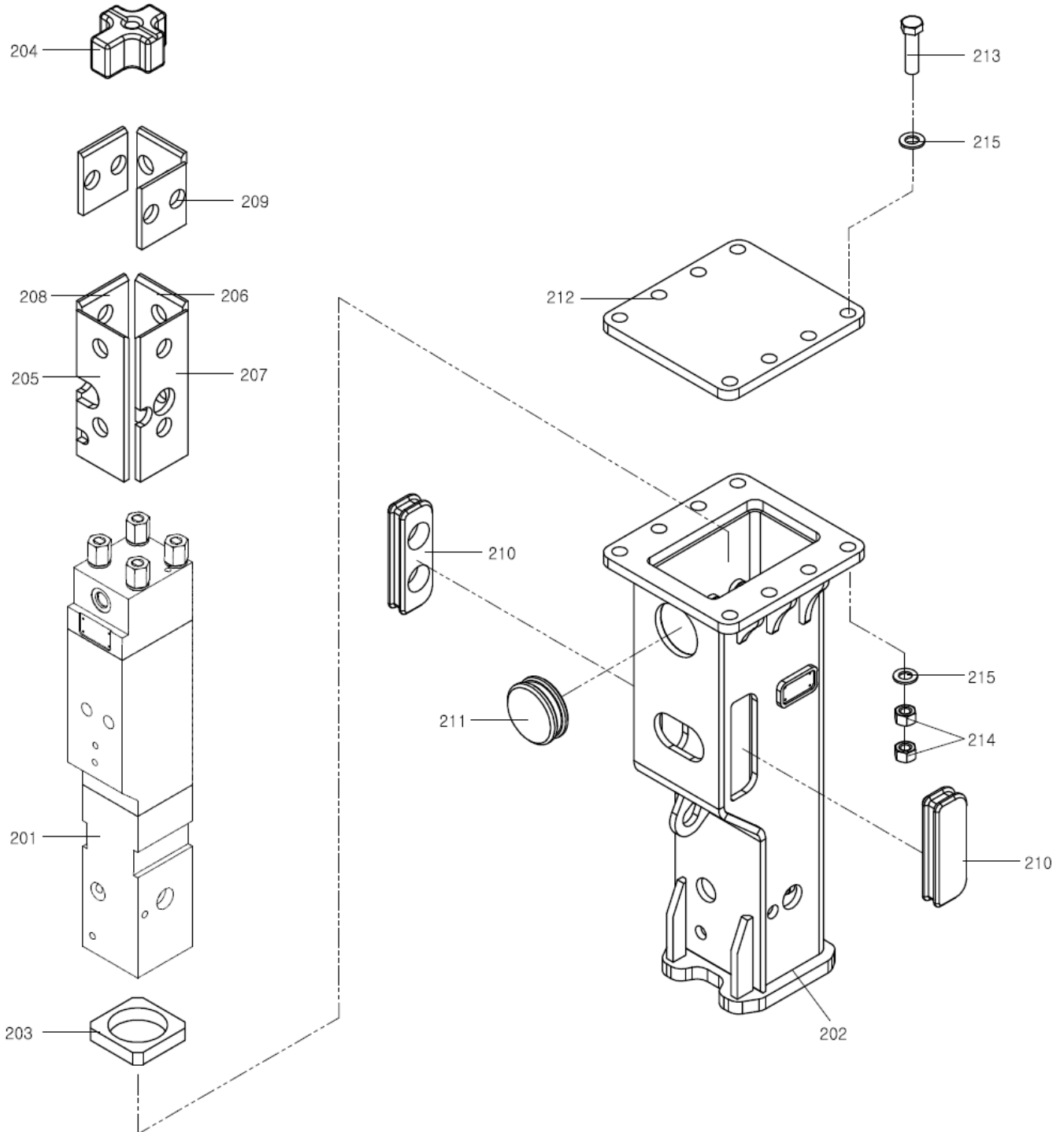

V2GS Housing Parts List

No.	Part No.	Part Name	Q'ty	Note
201	-	Hammer Assembly	1	
202	A02V2010	Housing Assembly	1	
203	A0202080	Base Buffer	1	
204	A0302160	Top Buffer	1	
205	A0202090	Wearing Plate	1	
206	A0202100	Wearing Plate	1	
207	A0202110	Wearing Plate	1	
208	A0202120	Wearing Plate	1	
209	A0302140	Wearing Plate	3	
210	A0602190	Side Rubber	2	
211	A0602180	Front Rubber	1	
212	A0202130	Top Plate	1	
213	HB1825065	Bolt	8	
	HB1825075	Bolt	8	
214	NN182500	Nut	16	
215	PW180000	P/Washer	16	

7.2 V2GS Hammer Assembly

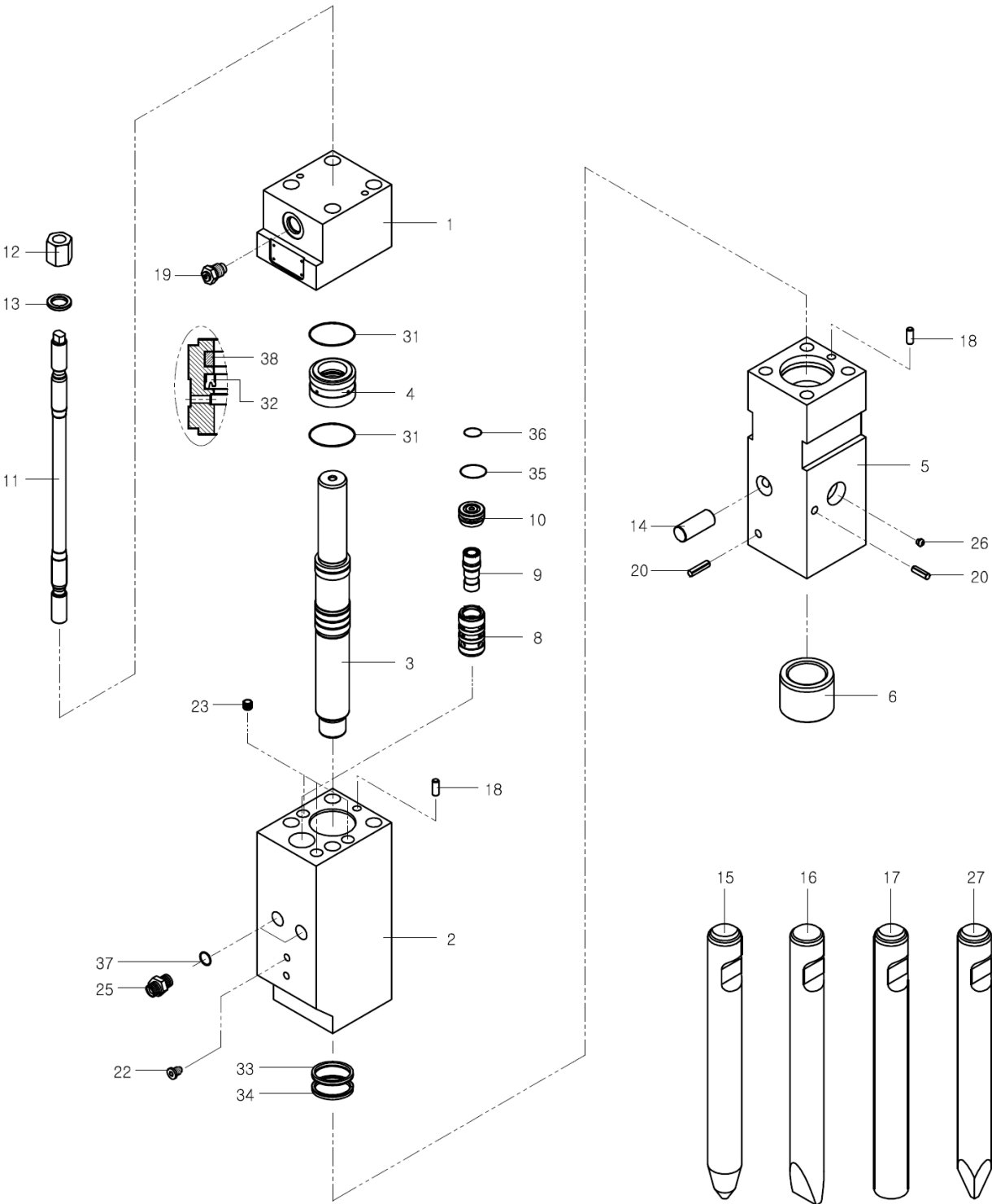

V2G Hammer Assembly Parts List

No.	Part No.	Part Name	Q'ty	Note
1	A0206010	Back Head	1	
2	A0206020	Cylinder	1	
3	A0206020	Piston	1	
4	A0206040	Seal Housing	1	
5	A0206050	Front Head	1	
6	A0206060	Tool Bushing	1	
8	A0206070	Oper. Valve Guide	1	
9	A0206080	Oper. Valve Spool	1	
10	A0206090	Valve Plug	1	
11	A0206100	Side Rod	4	
12	A0206110	Side Rod Nut	4	
13	A0206120	Side Rod Washer	4	
14	A0206130	Tool Pin	1	
15	A0206140	Tool – Cone	1	
16	A0206150	Tool - Chisel	1	
17	A0206160	Tool - Blunt	1	
18	B4006370	Guide Pin	2	
19	A3006590	Gas Charging Valve	1	
20	SP100000	Spring Pin	2	
22	B4006450	Hex. Socket Plug	1	
23	A0406200	Plug	3	
25	A0206180	Adapter	2	
26	B4006560	Grease Nipple	1	
27	A0206300	Tool - Moil	1	
31	B2507200	O – Ring	2	
32	A0207020	U – Packing	1	
33	A0207030	U – Packing	1	
34	A0207040	Wiper	1	
35	A0207050	O – Ring	1	
36	B4007310	O - Ring	1	
37	A0207070	O - Ring	2	
38	A0207080	Gas Seal	1	

*Vulcan Attachments Inc. is not responsible for errors and omissions to the content of this manual. Specifications are subject to change without notice.



VULCAN
ATTACHMENTS

Box 73 Stn St. Norbert Winnipeg, MB R3V 1L5

Toll-Free: 877-494-4303

Phone: 204-269-1680 | Fax: 204-269-9017

info@vulcanattachments.com

www.VulcanAttachments.com

